



# Installation, Operation, and Maintenance

## Axiom™ High Efficiency Console Water-Source Heat Pump ½ to 1½ Tons—60 Hz



### Models

60 Hz  
50 Hz

### "E" and later design

GECE - 006, 009, 012, 015, 018  
GECE - 006, 009, 012, 015

### **⚠ SAFETY WARNING**

Only qualified personnel should install and service the equipment. The installation, starting up, and servicing of heating, ventilating, and air-conditioning equipment can be hazardous and requires specific knowledge and training. Improperly installed, adjusted or altered equipment by an unqualified person could result in death or serious injury. When working on the equipment, observe all precautions in the literature and on the tags, stickers, and labels that are attached to the equipment.



# Warnings, Cautions and Notices

**Warnings, Cautions and Notices.** Note that warnings, cautions and notices appear at appropriate intervals throughout this manual. Warnings are provide to alert installing contractors to potential hazards that could result in death or personal injury. Cautions are designed to alert personnel to hazardous situations that could result in personal injury, while notices indicate a situation that could result in equipment or property-damage-only accidents.

Your personal safety and the proper operation of this machine depend upon the strict observance of these precautions.

Read this manual thoroughly before operating or servicing this unit.

---

**ATTENTION:** Warnings, Cautions and Notices appear at appropriate sections throughout this literature. Read these carefully:

- |                  |   |
|------------------|---|
| <b>⚠ WARNING</b> | Indicates a potentially hazardous situation which, if not avoided, could result in death or serious injury.   |
| <b>⚠ CAUTION</b> | Indicates a potentially hazardous situation which, if not avoided, could result in minor or moderate injury. It could also be used to alert against unsafe practices. |
| <b>NOTICE:</b>   | Indicates a situation that could result in equipment or property-damage only accidents  |
- 

## Important Environmental Concerns!

Scientific research has shown that certain man-made chemicals can affect the earth's naturally occurring stratospheric ozone layer when released to the atmosphere. In particular, several of the identified chemicals that may affect the ozone layer are refrigerants that contain Chlorine, Fluorine and Carbon (CFCs) and those containing Hydrogen, Chlorine, Fluorine and Carbon (HCFCs). Not all refrigerants containing these compounds have the same potential impact to the environment. Trane advocates the responsible handling of all refrigerants-including industry replacements for CFCs such as HCFCs and HFCs.

## Responsible Refrigerant Practices!

Trane believes that responsible refrigerant practices are important to the environment, our customers, and the air conditioning industry. All technicians who handle refrigerants must be certified. The Federal Clean Air Act (Section 608) sets forth the requirements for handling, reclaiming, recovering and recycling of certain refrigerants and the equipment that is used in these service procedures. In addition, some states or municipalities may have additional requirements that must also be adhered to for responsible management of refrigerants. Know the applicable laws and follow them.

<p style="text-align: center;"><b>⚠ WARNING</b></p> <p><b>Proper Field Wiring and Grounding Required!</b></p> <p>All field wiring <b>MUST</b> be performed by qualified personnel. Improperly installed and grounded field wiring poses <b>FIRE</b> and <b>ELECTROCUTION</b> hazards. To avoid these hazards, you <b>MUST</b> follow requirements for field wiring installation and grounding as described in <b>NEC</b> and your local/state electrical codes. Failure to follow code could result in death or serious injury.</p>
---

**⚠ WARNING****Personal Protective Equipment (PPE) Required!**

Installing/servicing this unit could result in exposure to electrical, mechanical and chemical hazards.

- Before installing/servicing this unit, technicians **MUST** put on all Personal Protective Equipment (PPE) recommended for the work being undertaken. **ALWAYS** refer to appropriate MSDS sheets and OSHA guidelines for proper PPE.
- When working with or around hazardous chemicals, **ALWAYS** refer to the appropriate MSDS sheets and OSHA guidelines for information on allowable personal exposure levels, proper respiratory protection and handling recommendations.
- If there is a risk of arc or flash, technicians **MUST** put on all Personal Protective Equipment (PPE) in accordance with NFPA 70E or other country-specific requirements for arc flash protection, **PRIOR** to servicing the unit.

Failure to follow recommendations could result in death or serious injury.

## Trademarks

Trane and the Trane logo are trademarks of Trane in the United States and other countries. All trademarks referenced in this document are the trademarks of their respective owners.



# Table of Contents

General Information .....	5
Jobsite Inspection .....	5
Jobsite Storage .....	5
Model Number Description .....	6
Unit Dimensions and Weights .....	7
Unit Clearance .....	7
Installation .....	21
Performance Data .....	24
Operating Pressures .....	24
Water Pressure Drop .....	27
Water Volume .....	27
Electrical Data .....	28
Pre-Start .....	30
Pre-Startup Checklist .....	30
Start-Up .....	31
Initial Unit Start-up .....	31
Maintenance .....	33
Preventive Maintenance .....	33
Filter Replacement (standard height configuration) .....	33
Filter Replacement (low height configuration) .....	34
Troubleshooting .....	35
Deluxe Controls .....	36
Unit Wiring .....	37
Warranty .....	43
Standard Warranty .....	43
Extended Warranty .....	43

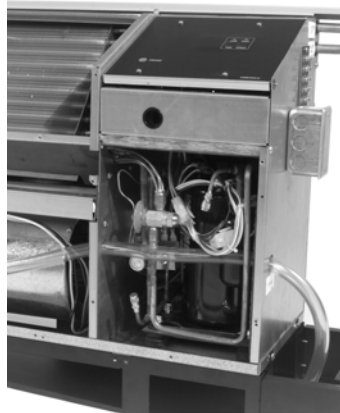
# General Information

## Jobsite Inspection

Each unit has been inspected, tested and operated at the factory by production and quality associates prior to being crated for safe transit. However, rough handling or accidents can occur resulting in damaged equipment being delivered. Always perform the following checks before accepting a unit:

1. Do not sign the bill of lading accepting the unit(s) until inspection has been completed. Check for damage promptly after the unit(s) are unloaded. Once the bill of lading is signed at the jobsite, the unit(s) are now the property of the SOLD TO party and future freight claims MAY NOT be accepted by the freight company.
2. Check the unit model numbers on the bill of lading against those ordered and received to assure equipment is AS ORDERED.
3. Check to assure that the refrigerant charge has been retained during shipment by use of gauges. Schrader taps are located and labeled internal to the cabinet. (See [Figure 1](#)).

**Figure 1. Schrader location**



**Important:** After assuring that charge has been retained re-install schrader caps to assure that refrigerant leakage does not occur and unit panel using all factory provided screws.

## Jobsite Storage

This unit is intended for indoor use only. To protect the unit from damage due to the elements, and to prevent possible IAQ contaminant sources from growing, the unit should be stored indoors. If indoor storage is not possible, the following provisions for outdoor storage must be met.

1. Place the unit(s) on a dry surface or raise above the ground to assure adequate air circulation beneath the unit. This is to assure that no portion of the unit contacts standing water at any time.
2. Cover the unit(s) with a water proof tarp to protect them from the elements.
3. Make provisions for continuous venting of the covered units to prevent moisture from standing on the unit(s) surfaces. Wet interior unit insulation can become an amplification site for microbial growth which has been determined to be a cause of odors and serious health related indoor air quality problems.
4. Store units in the normal UP orientation. Storing units in this manner maintains oil in the compressor.
5. Units may be stacked two high.

**Important:** Equipment is shipped FOB (Free on Board) at the manufacturer. Therefore, freight claims for damages against the carrier must be initiated by the receiver.



# Model Number Description

## Digit 1-3: Unit Configuration

GEC = High Efficiency Console

## Digit 4: Development Sequence

E

## Digits 5-7: Nominal Capacity

006 = 1/2 Ton

009 = 3/4 Ton

012 = 1 Ton

015 = 1 1/4 Ton

018 = 1 1/2 Ton

## Digit 8: Voltage (Volts/Hz/Phase)

0 = 115/60/1

1 = 208/60/1

2 = 230/60/1

6 = 220-240/50/1

7 = 265/60/1

## Digit 9: Heat Exchanger

1 = Copper-Water Coil

2 = Cupro-Nickel Water Coil

## Digit 10: Current Design Sequence

A

## Digit 11: Refrigeration Circuit

0 = Heating and Cooling Circuit

2 = Heating and Cooling Circuit with Hot Gas Reheat

## Digit 12: Blower Configuration

1 = Standard Blower Motor

## Digit 13: Freeze Protection

0 = None or Standard

A = 20° Freezestat

B = 35° Freezestat

## Digit 14: Open Digit

0 = Open Digit

S = Design Special

## Digit 15: Supply-Air Arrangement

0 = Standard Supply-Air Arrangement

S = Design Special

## Digit 16: Return-Air Arrangement

0 = Standard Return-Air Arrangement

S = Design Special

## Digit 17: Control Types

0 = Basic 24V Controls

D = Deluxe 24V Controls

C = Tracer ZN510 Controls

B = Tracer ZN524 Controls

E = Deluxe 24V Control with Low Temp Unoccupied Sensor & Programmable Thermostat

## Digit 18: Tstat/Sensor Location

0 = Wall Mounted Location

1 = Unit Mounted Location with Standard Entry

2 = Unit Mounted Location with Key lock Entry

## Digit 19: Fault Sensors

0 = No Fault Sensor

1 = Condensate Overflow Sensor

2 = Filter Maintenance Timer

3 = Condensate Overflow and Filter Maintenance Timer

4 = Fan Status Sensor

6 = Condensate Overflow and Fan Status

H = Fan Status and Filter Maintenance Timer

J = Fan Status, Filter Maintenance Timer and Condensate Overflow Sensor

## Digit 20: Temperature Sensor

0 = No Additional Temperature Sensor

1 = Entering Water Sensor

## Digit 21: Open Digit

0 = Open Digit

## Digit 22: Electric Heat

0 = No Electric Heat

2 = Boilerless Control Electric Heat (minimum)

3 = Boilerless Control Electric Heat (maximum)

## Digit 23: Unit Mounted Disconnect

0 = No Unit Mounted Disconnect

A = Power Cord/Receptacle Box

B = Power Cord/Receptacle Box with Circuit Breaker

C = On/Off Toggle Switch

## Digit 24: Filter Type

0 = No Filter; Chassis Only

1 = 1" Throwaway Filter

A = 1" Pleated Filter

## Digit 25: Acoustic Arrangement

0 = Enhanced Sound Attenuation

## Digit 26: Factory Configuration

0 = Standard Factory Configuration (*Chassis, Cabinet and Subbase*)

1 = Chassis ONLY

2 = Low Height Factory Configuration (*Chassis, Cabinet and Subbase*)

3 = Extended Length Factory Configuration (*Chassis, Cabinet and Subbase*)

## Digit 27: Paint Color

0 = No Paint Selection Available

1 = Deluxe Beige

2 = Cameo White

3 = Soft Dove

## Digit 28: Outside Air

0 = No Outside Air Option

1 = Outside Air Opening

2 = Motorized Outside Air (*2-position*)

## Digit 29: Piping Arrangement

L = Left Hand Piping Arrangement

R = Right Hand Piping Arrangement

## Digit 30-36: Does Not Apply to GEC

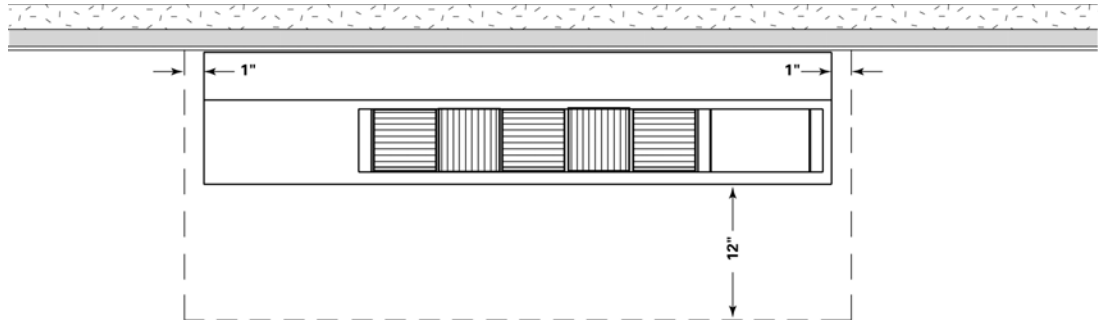
0000000 = Digits 30-36 are not applicable to the GEC product

# Unit Dimensions and Weights

## Unit Clearance

Access to the unit for servicing purposes should be provided at installation. All configurations require clearance from other mechanical and electrical equipment on three service sides (shown below). This enables panel removal from the unit for service/maintenance ability.

**Figure 2. Unit clearances**

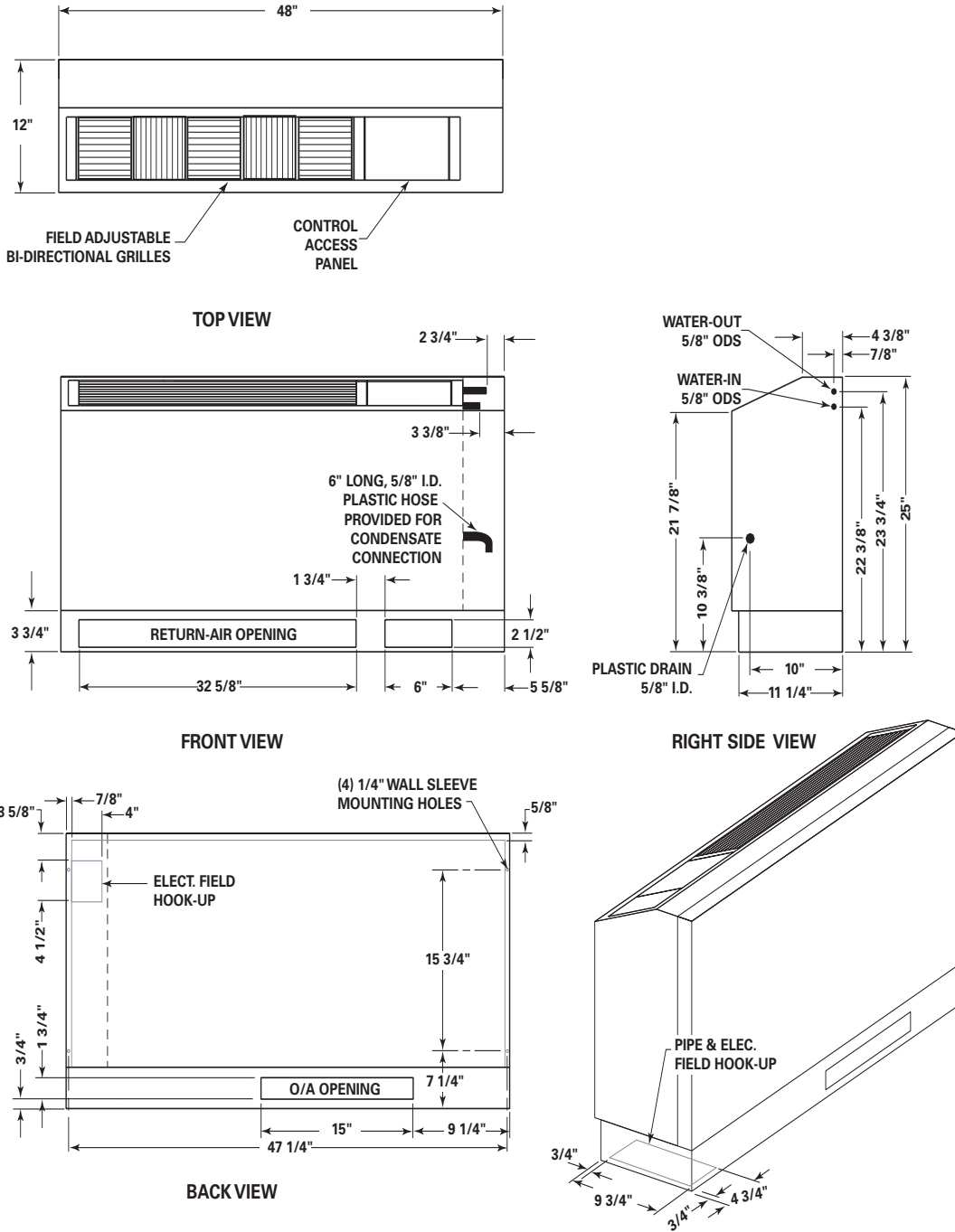


**Table 1. Unit weights**

Unit Size		Without Pallet		With Pallet	
60 Hz	50 Hz	Unit Weight (lbs)	Chassis Weight (lbs)	Unit Weight (lbs)	Chassis Weight (lbs)
006	—	188	140	218	170
009	006	189	141	219	171
012	009	210	162	240	192
015	012	204	156	234	186
018	015	212	164	242	194

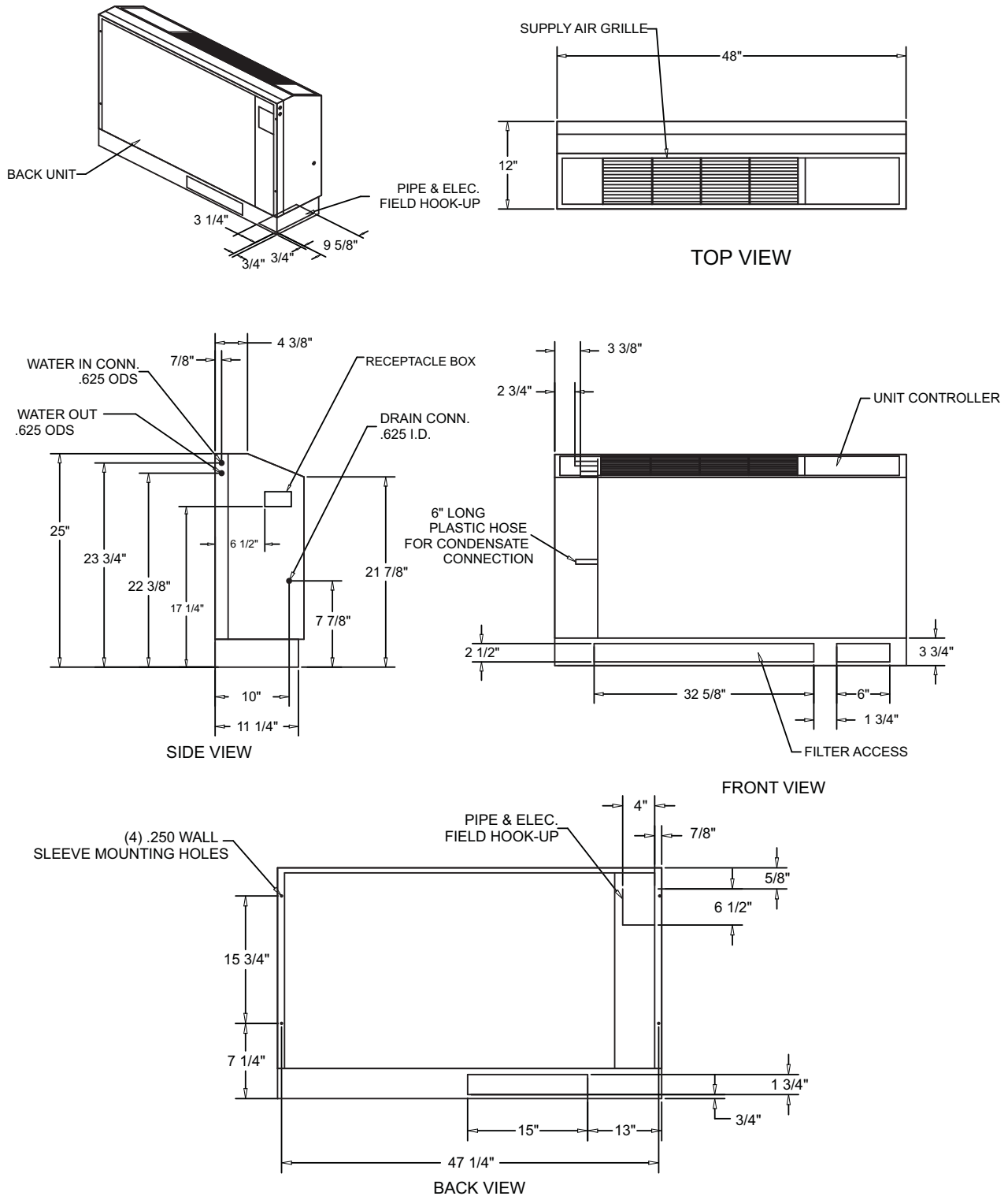
## Unit Dimensions and Weights

Figure 3. GECE 006-018 (60 Hz); GECE 006-015 (50 Hz)—cabinet (RH) piping connection





**Figure 4. GECE 006-018 (60 Hz); GECE 006-015 (50 Hz)—cabinet (LH) piping connection**



## Unit Dimensions and Weights

Figure 5. GECE 006-018 (60 Hz); GECE 006-015 (50 Hz)—subbase (RH)

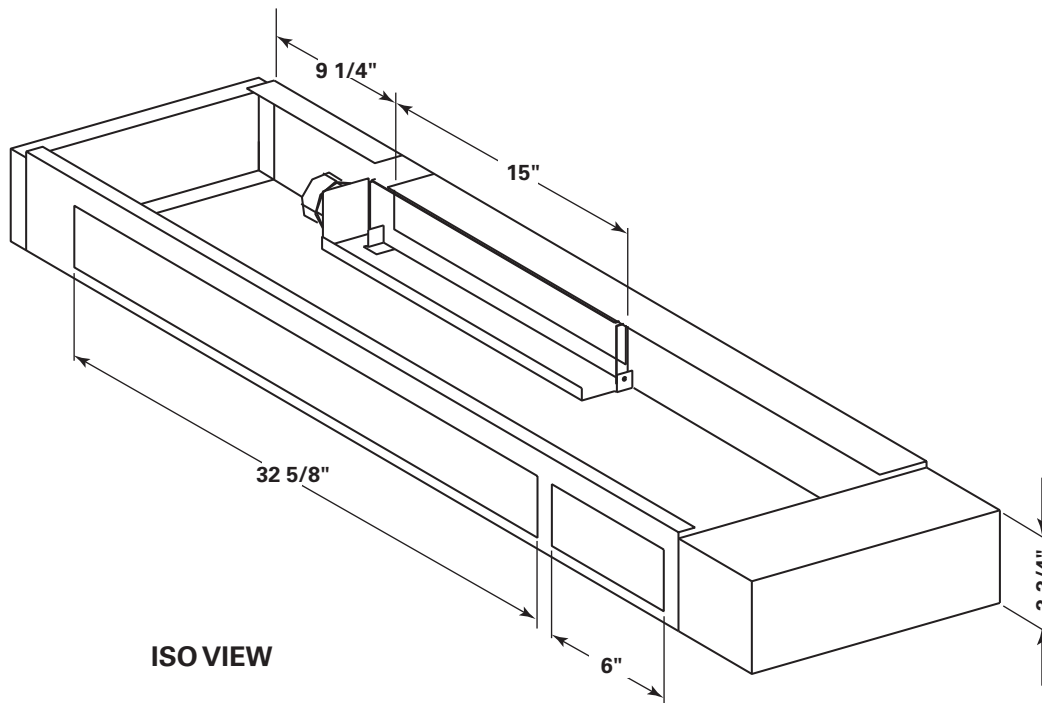
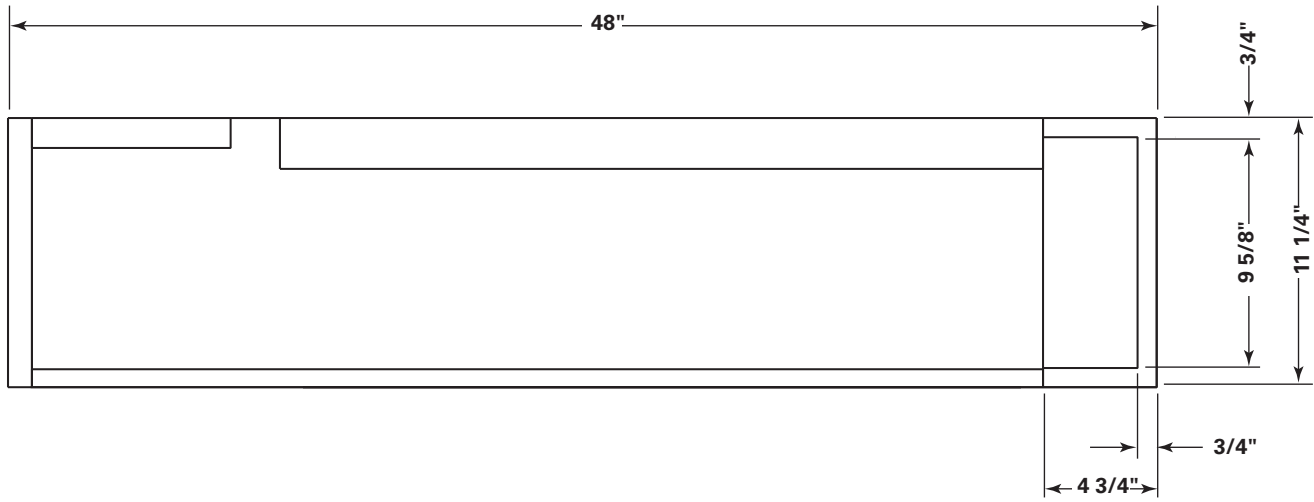
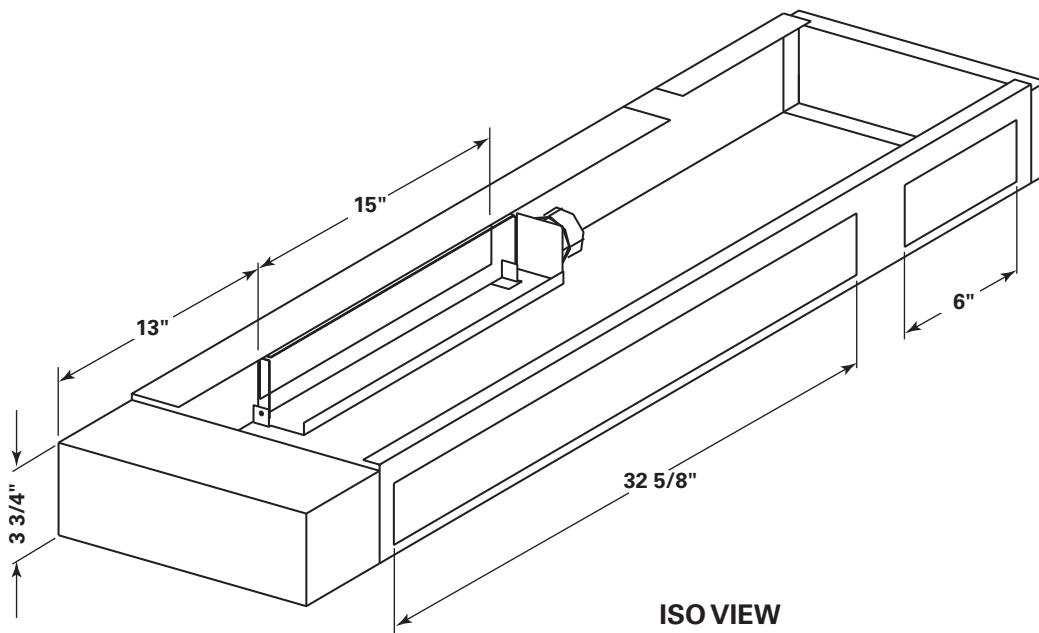
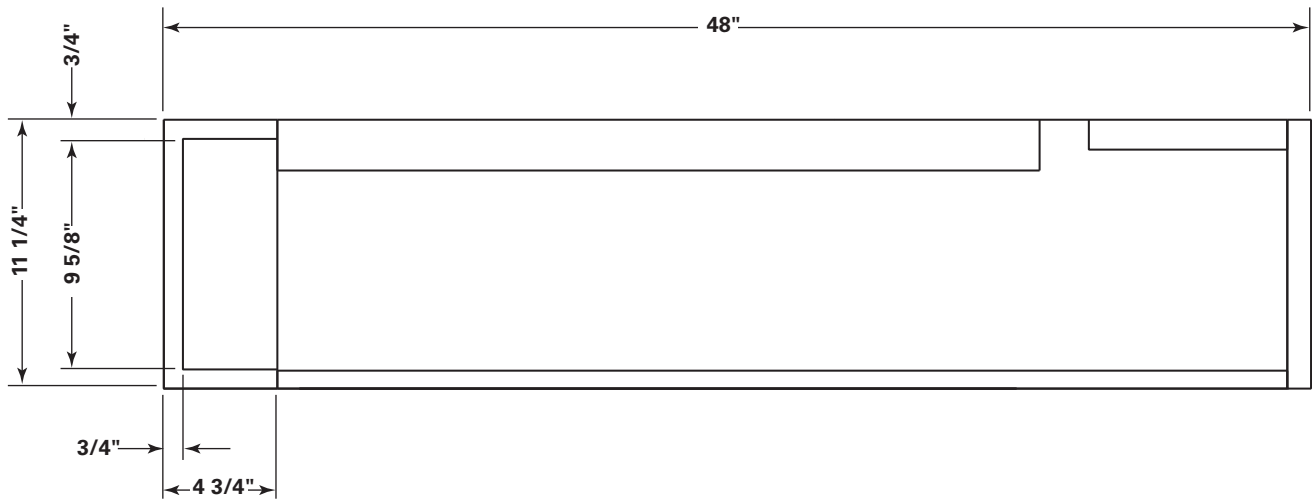
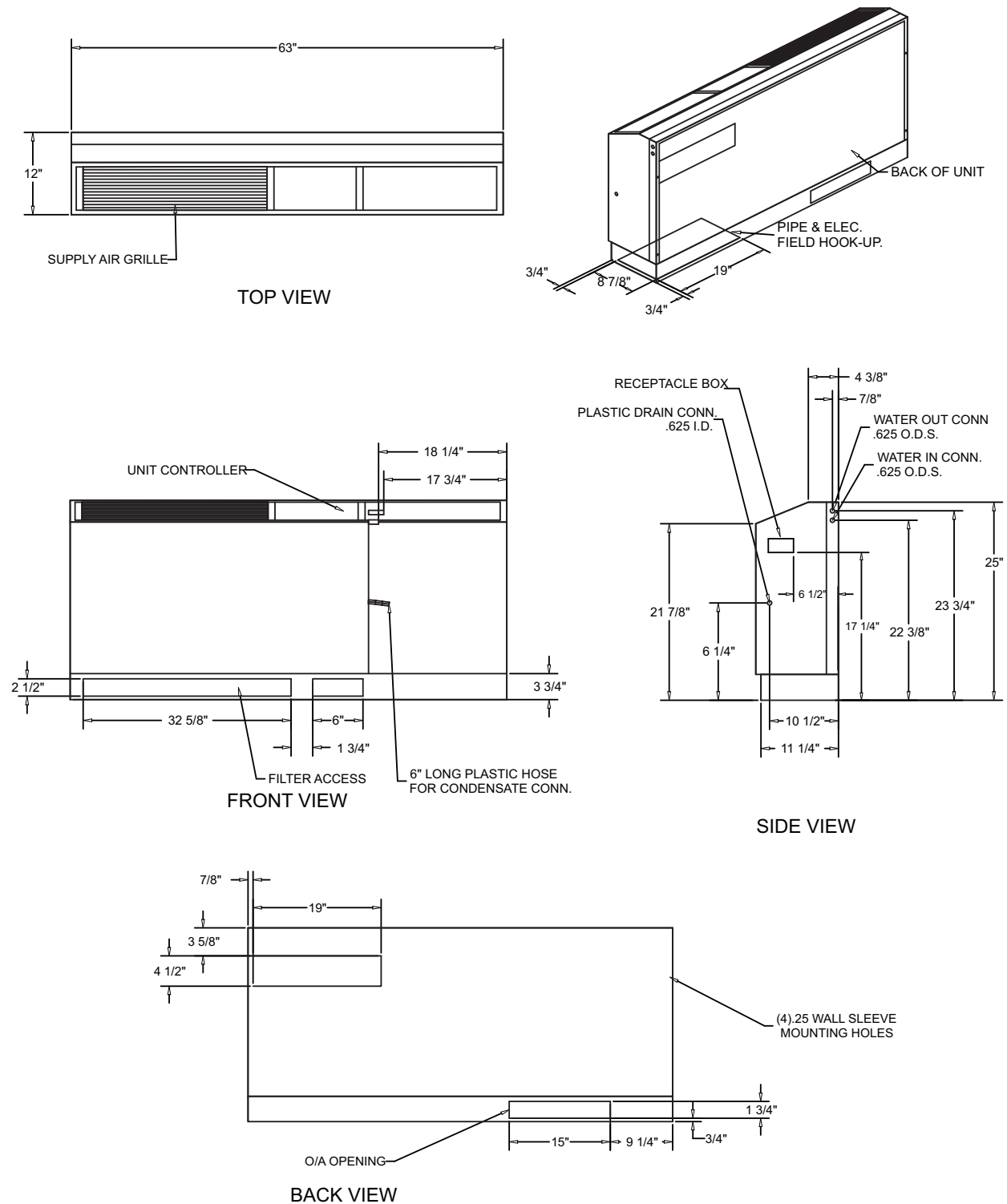


Figure 6. GECE 006-018 (60 Hz); GECE 006-015 (50 Hz)—subbase (LH)

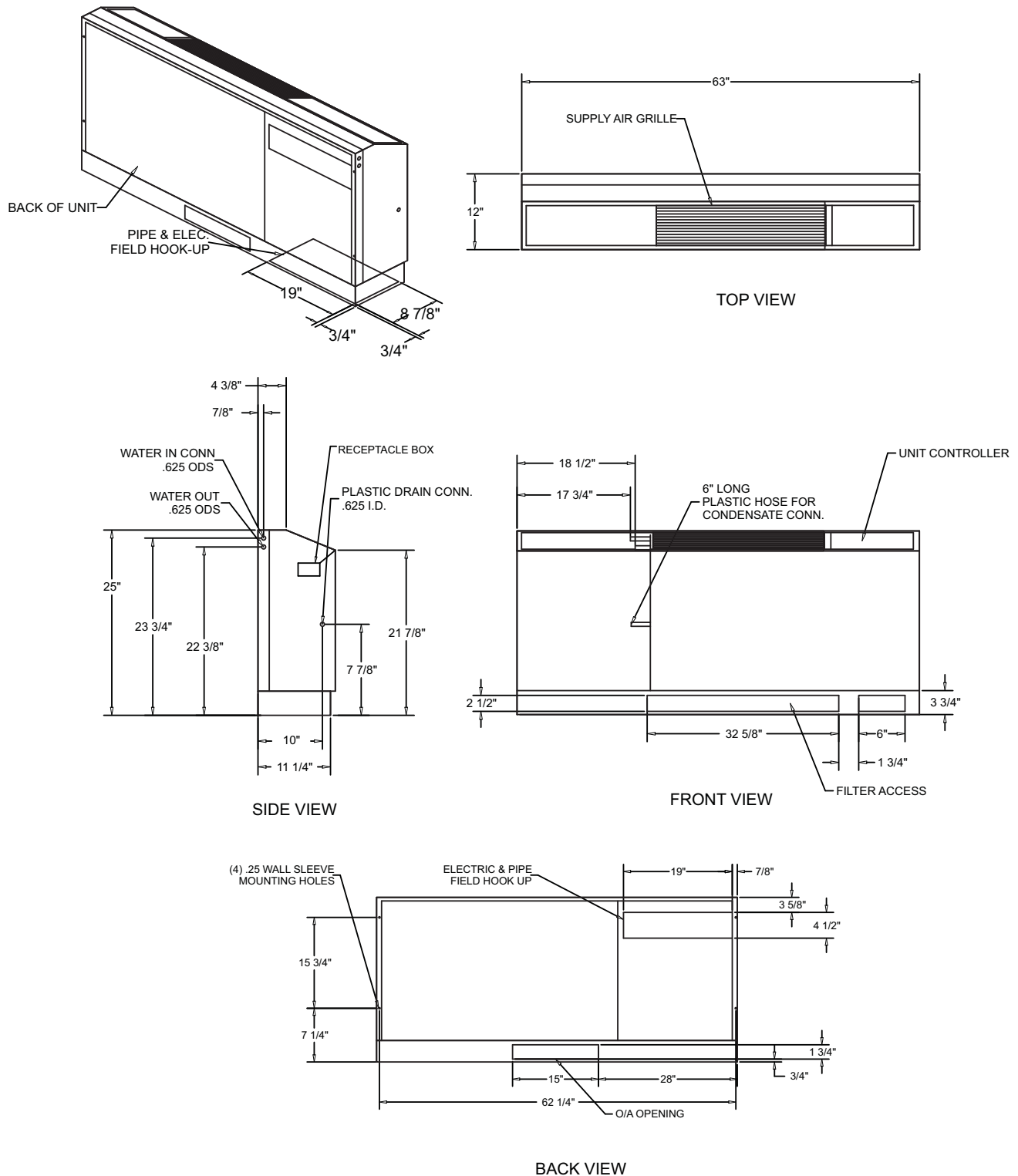


## Unit Dimensions and Weights

Figure 7. GECE 006-018 (60 Hz); GECE 006-015 (50 Hz)—cabinet (RH) piping extended length

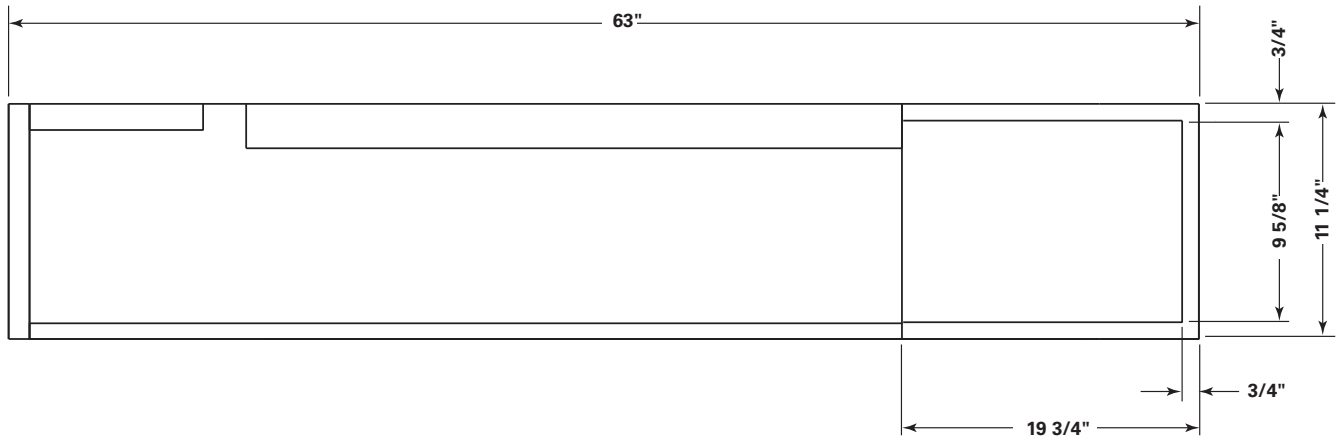


**Figure 8. GECE 006-018 (60 Hz); GECE 006-015 (50 Hz)—cabinet (LH) piping extended length**

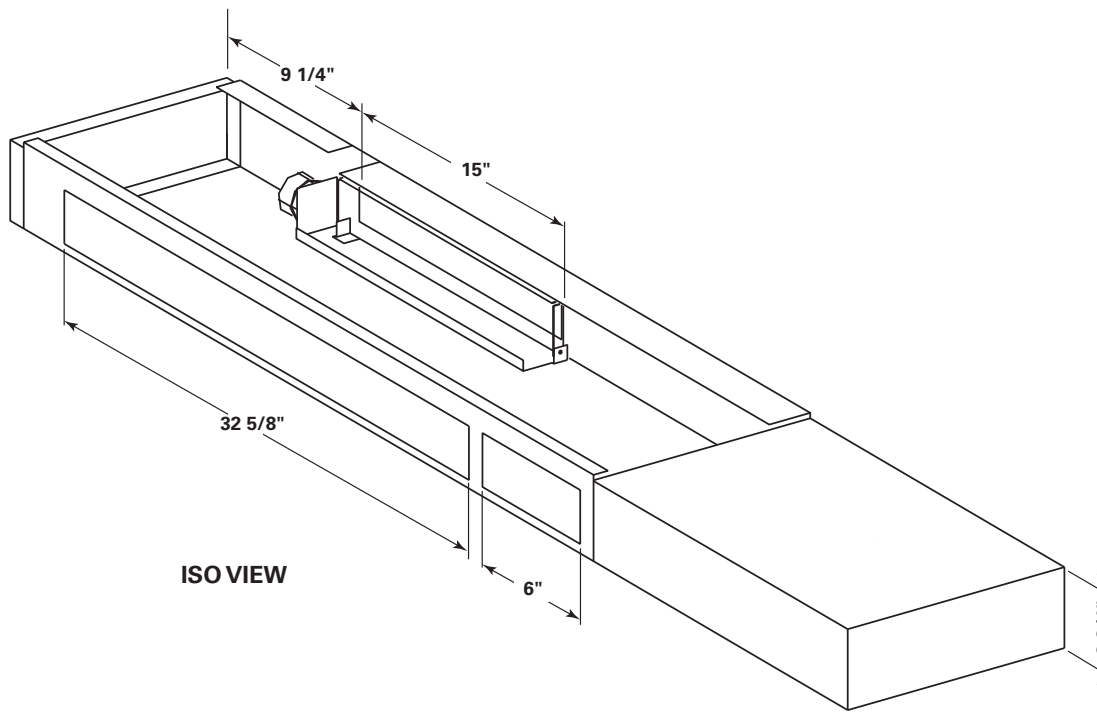


## Unit Dimensions and Weights

Figure 9. GECE 006-018 (60 Hz); GECE 006-015 (50 Hz)—subbase (RH) extended length

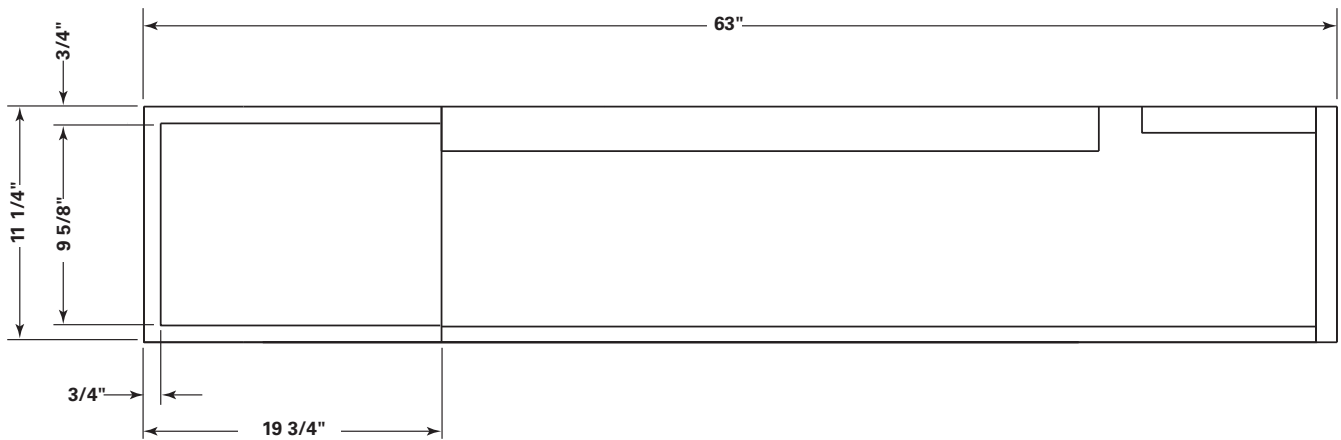


TOP VIEW

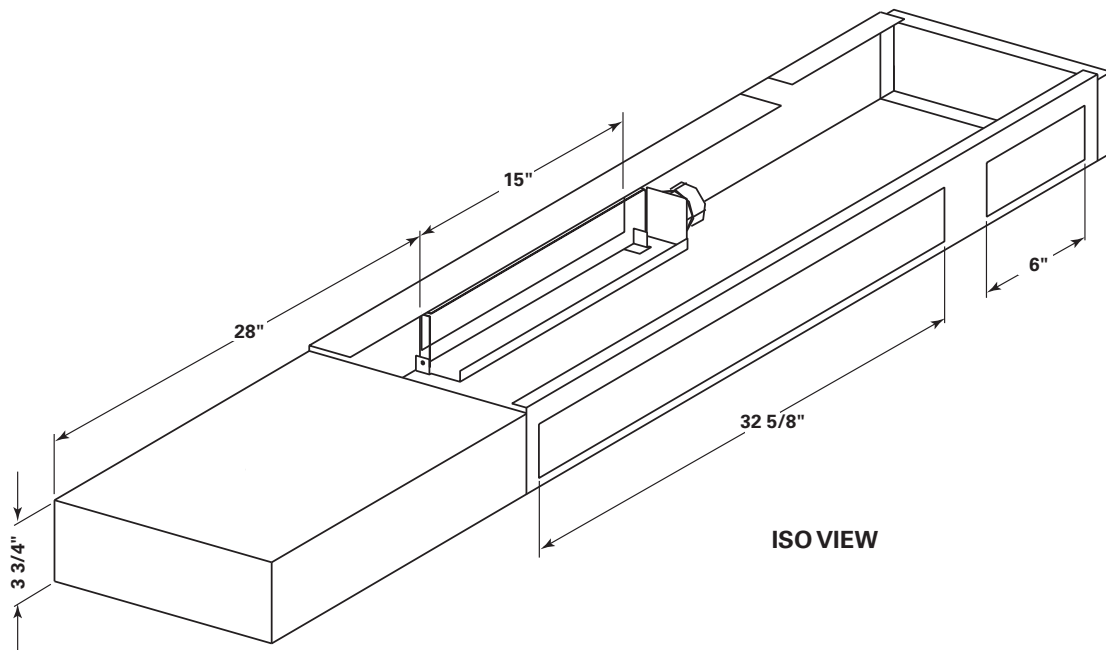


ISO VIEW

Figure 10. GECE 006-018 (60 Hz); GECE 006-015 (50 Hz)—subbase (LH) extended length



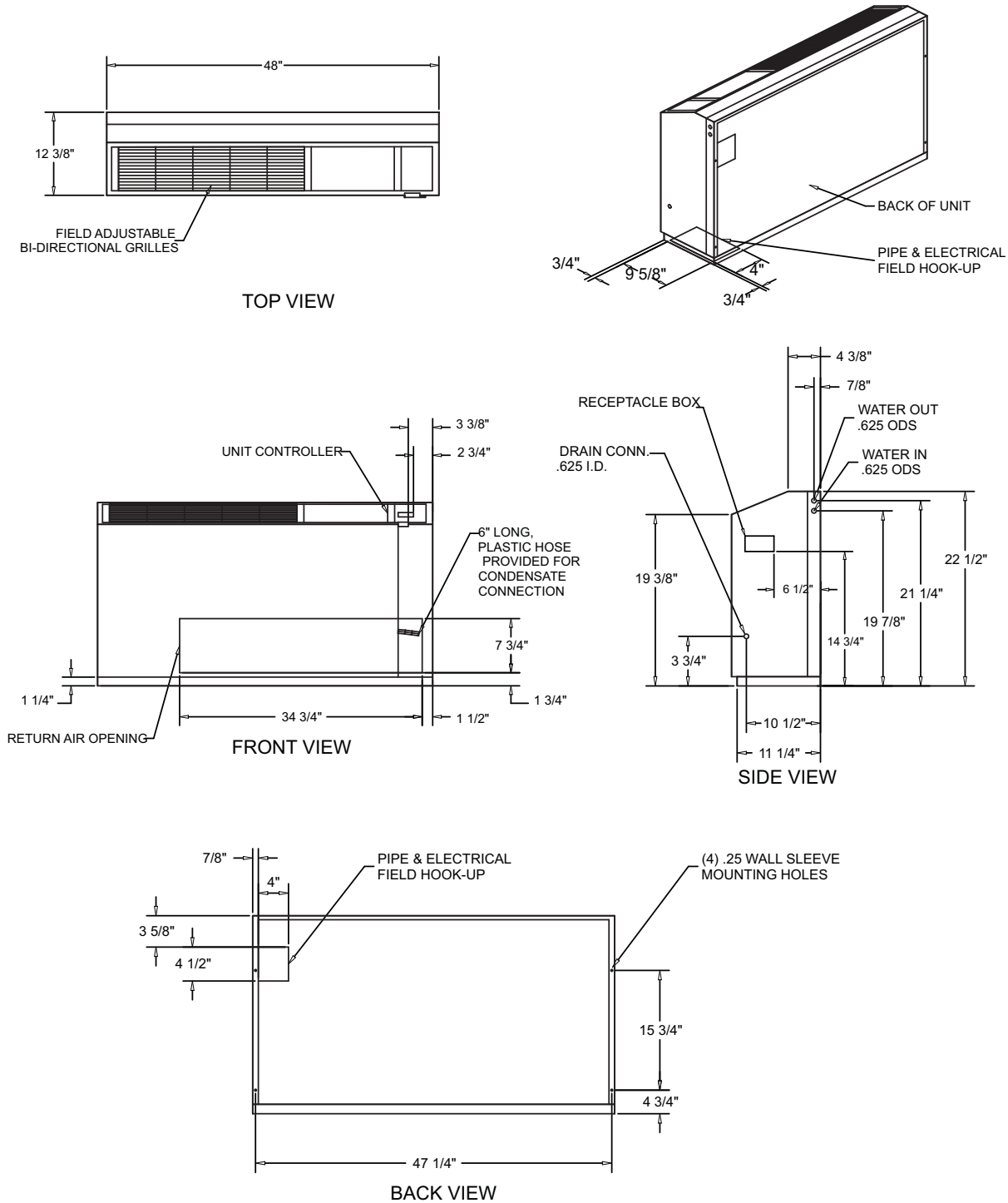
TOP VIEW



ISO VIEW

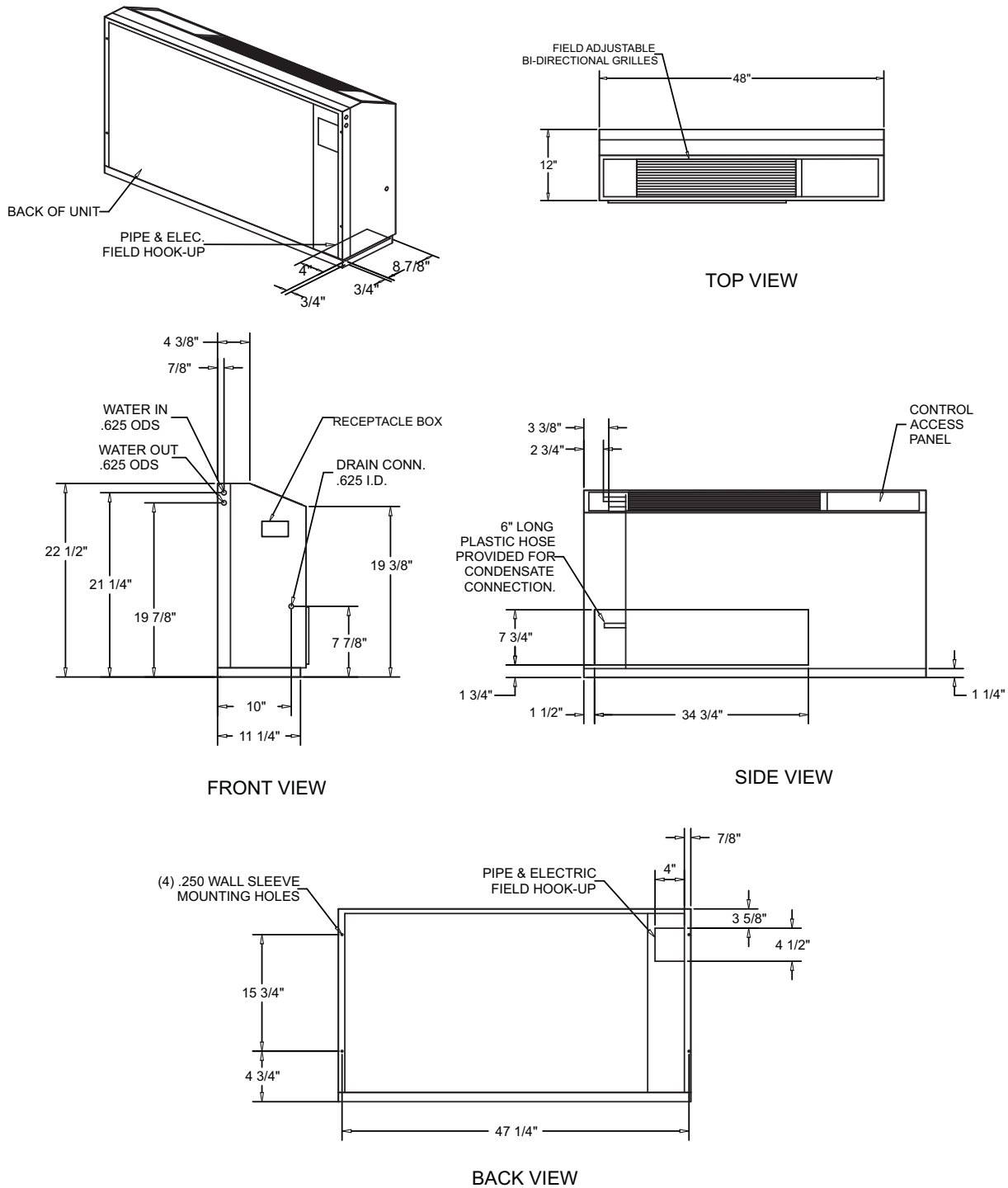
## Unit Dimensions and Weights

Figure 11. GECE 006-018 (60 Hz); GECE 006-015 (50 Hz)—cabinet (RH) low height unit



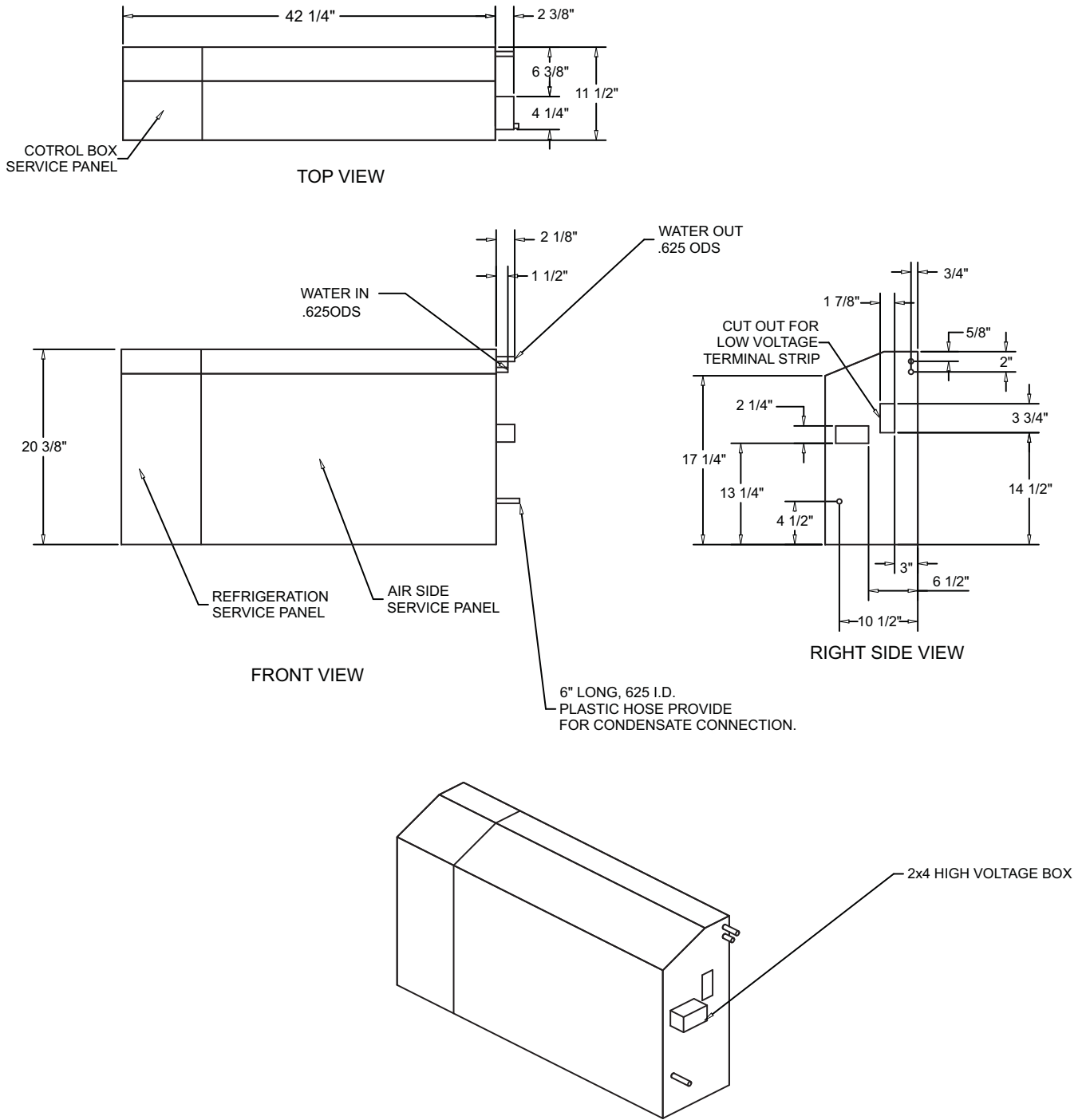


**Figure 12. GECE 006-018 (60 Hz); GECE 006-015 (50 Hz)—cabinet (LH) low height unit**

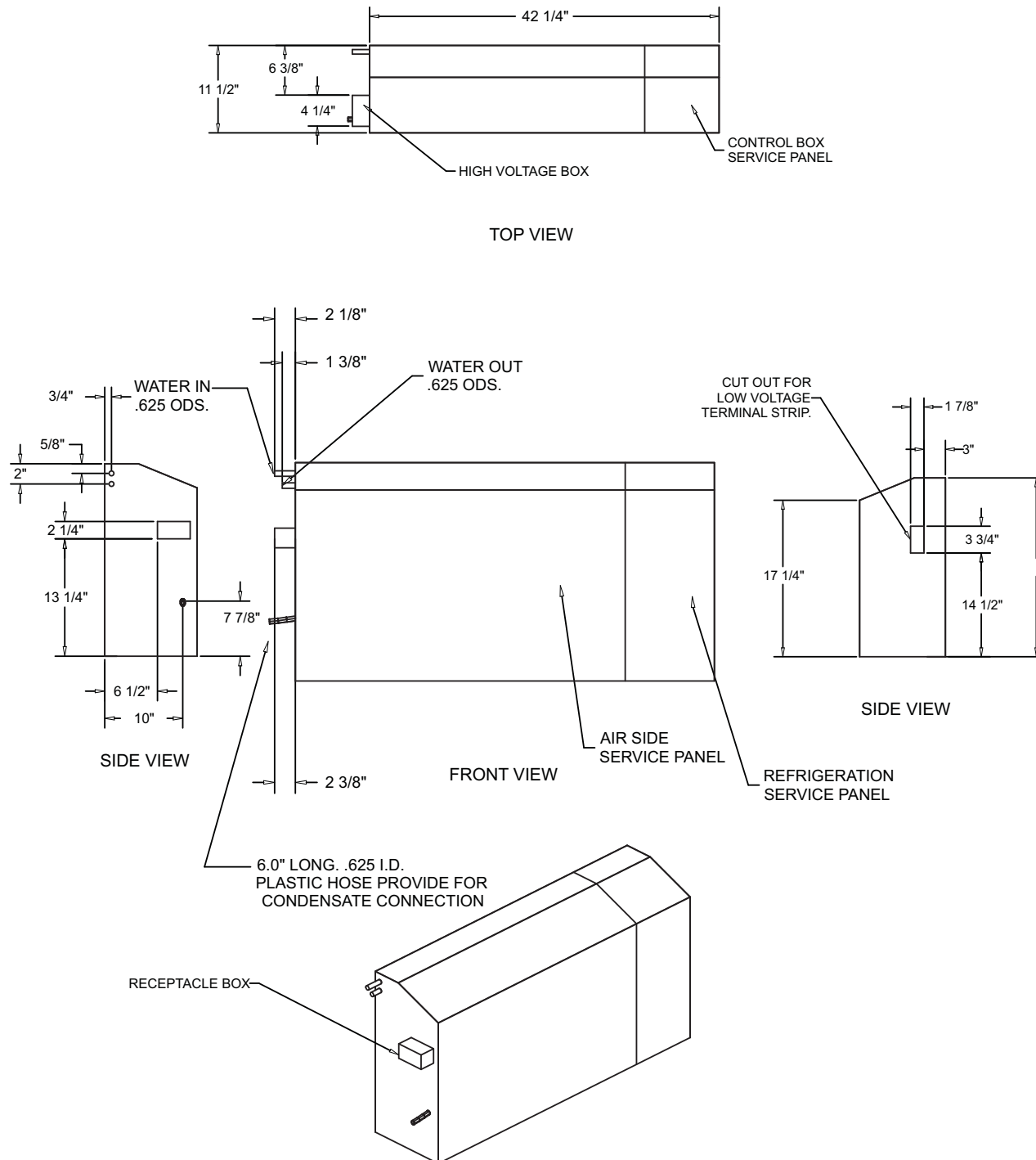


# Unit Dimensions and Weights

**Figure 13. GECE 006-018 (60 Hz); GECE 006-015 (50 Hz) —chassis (RH)**



**Figure 14. GECE 006-018 (60 Hz); GECE 006-015 (50 Hz) —chassis (LH)**





## Unit Dimensions and Weights

**Table 2. Models GECE 006–012**

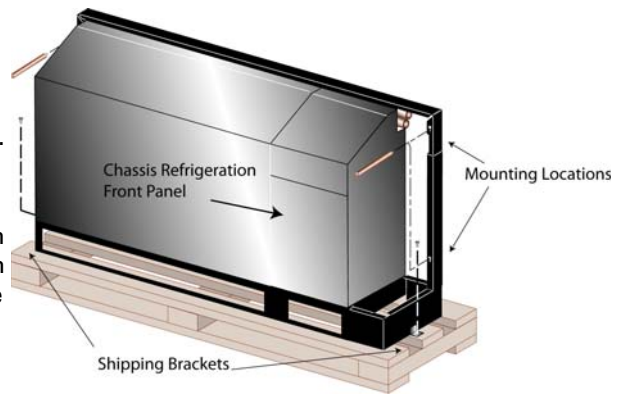
Model GEC		006	009	012
Unit Size	Length (in.)	48 or 63	48 or 63	48 or 63
	Height (in.)	25 or 22½	25 or 22½	25 or 22½
	Width (in.)	12 or 12 3/8	12 or 12 3/8	12 or 12 3/8
Compressor Type		Rotary	Rotary	Rotary
R-410A Refrigerant (lbs)	Heating and Cooling	1.47	1.50	1.57
	Hot Gas Reheat	1.56	1.59	1.66
Approximate Weight without Pallet (lbs)	Unit	188	189	210
	Chassis Only	140	141	162
Approximate Weight with Pallet (lbs)	Unit	218	219	240
	Chassis Only	170	171	192
Filter Size (standard height-25 in.)		1 x 10 x 32 3/8	1 x 10 x 32 3/8	1 x 10 x 32 3/8
Filter Size (low height-22½ in.)		1 x 7¾ x 30 5/8	1 x 7¾ x 30 5/8	1 x 7¾ x 30 5/8
Blower Wheel Size (in)		(1) 5¼ x 8 1/8	(2) 5¼ x 8 1/8	(2) 5¼ x 8 1/8

**Table 3. Models GECE 015–018**

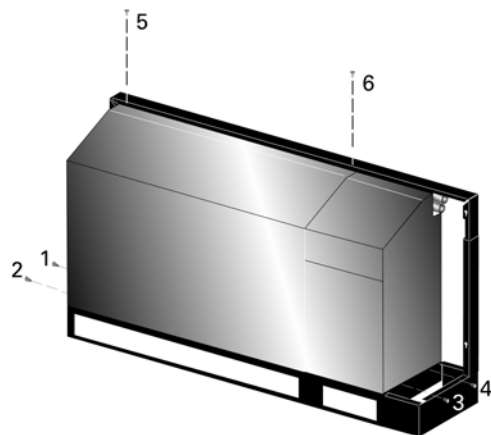
Model GEC		015	018
Unit Size	Length (in)	48 or 63	48 or 63
	Height (in)	25 or 22½	25 or 22½
	Width (in)	12 or 12 3/8	12 or 12 3/8
Compressor Type		Rotary	Rotary
R-410A Refrigerant (lbs)	Heating and Cooling	1.69	1.88
	Hot Gas Reheat	1.81	2.06
Approximate Weight without Pallet (lbs)	Unit	204	212
	Chassis Only	156	164
Approximate Weight with Pallet (lbs)	Unit	234	242
	Chassis Only	186	194
Filter Size (standard height-25 in.)		1 x 10 x 32 3/8	1 x 10 x 32 3/8
Filter Size (low height-22½ in.)		1 x 7¾ x 30 5/8	1 x 7¾ x 30 5/8
Blower Wheel Size (in.)		(2) 5¼ x 8 1/8	(2) 5¼ x 8 1/8

# Installation

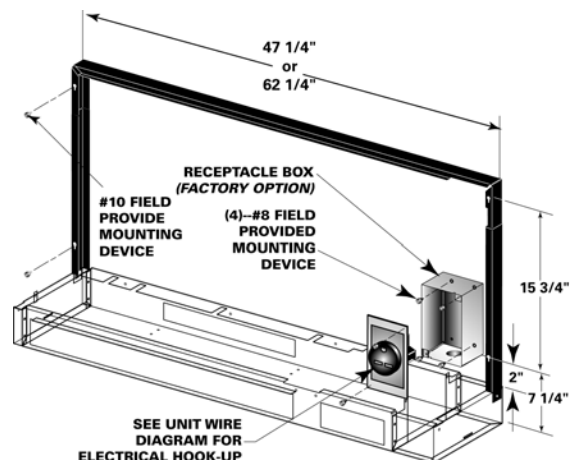
1. **Uncrate Unit.** Remove packaging and inspect the unit. Carefully remove the stretch wrap and cardboard pieces. The installation literature and may be found on the back of the unit in a clear, plastic bag. Unit has been tied to skid by (2) shipping brackets.
2. **Inspect Unit.** Remove refrigeration panel and inspect the unit. Be certain the refrigerant tubing has clearance from adjacent parts. Verify that the electrical connections are tight and in-place.



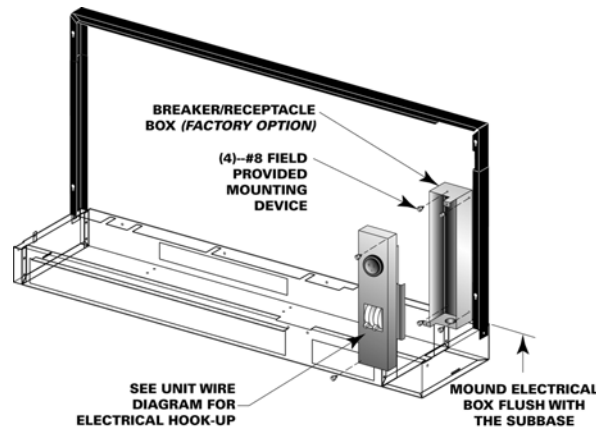
3. **Mounting to Wall.** With the chassis still on the subbase, align the unit to the wall. If unit contains an outside air option, align the wall cut-out to the subbase outside-air cut-out. Level the unit per plan requirements. Mark the four mounting locations for wall sleeve mounting to the wall. The dimensions should fall in line with [Step 5](#).
4. **Remove Chassis.** Remove the chassis from the subbase via 6 screws. The chassis is attached to both the subbase and the wall sleeve (see diagram above). To assure proper alignment, re-install screws 2 and 3 in the final installation of the unit ([Step 11](#)).



5. **Wall Flange.** After removing chassis from the subbase, install the wall flange assembly to the desired wall with the use of four #10-field provided screws. The wall flange assembly includes four, 1/4 in. diameter clearance holes.
6. **Mounting of Receptacle Box (receptacle box - OPTION).** Mounting of the receptacle box should be made prior to piping and electrical hook-up. This factory disconnect option is designed to fit inside the end pocket. Mount the receptacle box 2 in. above the top of the subbase with four, #8-field supplied screws.

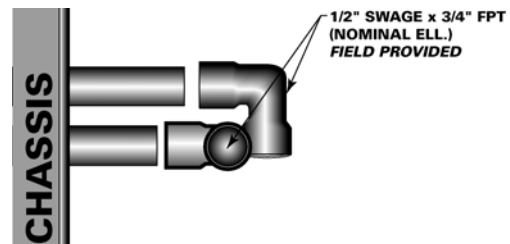


7. **Mounting of Receptacle Box (circuit breaker-OPTION).** Mounting of the circuit breaker/receptacle box should be made prior to piping and electrical hook-up. This factory disconnect option is designed to fit inside the end pocket. Mount the electrical box flush with the subbase with four, #8-field supplied screws.
8. **Wiring of Receptacle Box (OPTION).** Power wiring to the equipment should be installed per national and local electric codes by a professional electrician. Power wiring to the receptacle box may be done at this time. See the unit's wiring schematic for field wiring.



**Note:** *Factory Recommendation: Unit's receiving the circuit breaker option should have water and condensate piping supplied/returned through the bottom of the unit OR include the extended cabinet option.*

9. **Verify Fit-up.** Slide the chassis onto the subbase to verify that field installed receptacle box, condensate pipe, and supply/return pipe are in the appropriate locations and will not require adjustments. Verify water connection angle prior to brazing of the unit water-in/out.
10. **Water Connections.** With the chassis on or off of the subbase, install the field provided water connections to the unit water-in/out pipe. Trane recommends a 1/2 in. x 3/4 in. nominal ell to be field brazed to the factory 1/2 in. nominal water-in/out lines. Water in/out copper size: 5/8 in. ODS or 1/2 in. nominal.



11. **Replace Chassis.** Slide chassis back into place on the subbase. To assure proper alignment, reinstall the two front screws (2 and 3) that attach the chassis to the subbase.
12. **Field Piping.** Inspect the system water pipe thoroughly before connecting the unit to the system. Water-to-refrigerant heat exchanger fouling, freezing and failure is imminent if the system pipe contains contaminants. Water to refrigerant heat exchanger ships with nitrogen holding charge. Remove rubber plugs from heat exchanger. All field piping must be cleaned of contaminants.
13. **Connect Supply/Return Hoses.** Connect the supply and return line to the unit inlet and outlet. Flexible hoses reduce vibration from the water lines to the unit. An isolation valve, p/t plugs and auto-flow valves are recommended to separate the closed/open loop from the mechanical device.
14. **Connecting the Drain.** Because the console configuration is a blow-through design, no condensate trapping is necessary. However, it is necessary for the condensate to run in a downward motion to allow gravity to properly drain the system. The unit drain connection is 5/8 in. I.D. or 7/8 in. O.D. for all GECE 006-018 systems.

## ⚠ WARNING

### Grounding required!

Follow proper local and state electrical code on requirements for grounding. Failure to follow code could result in death or serious injury.

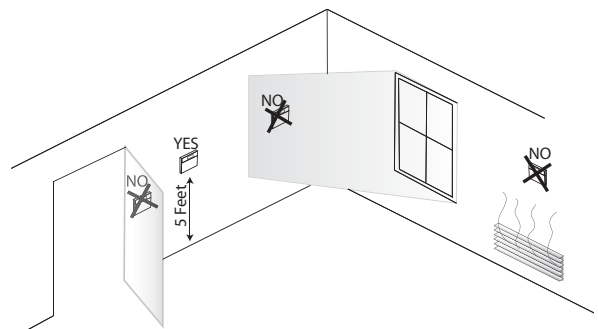
15. **Wiring Connections.** Power wiring to the equipment should be installed per national and local electric codes by a professional electrician. Refer to [Step 6](#), [Step 7](#), and [Step 8](#) for units that include the factory supplied receptacle box.

For units containing a field provided disconnect, or, are hard wired to the unit, Trane provides pig tail leads inside a 2 x 4 handy-box in either the right or left side end pocket. See unit wiring schematic for details.

For units containing a wall mounted thermostat, a low voltage (18-pole) terminal strip is provided for field installation of the thermostat. See [Step 18](#) for unit mounted controls.

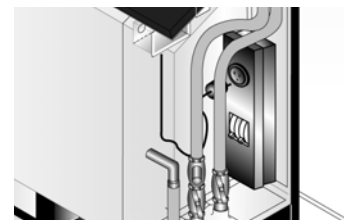
16. **Wall Mounted Control.** The thermostat hook-up to the unit is made at the unit mounted 24V (18-pole) low voltage terminal strip. This strip is mounted on the exterior of the control box on the right side of the unit. For units that contain left hand piping, a low voltage crossover to the 18-pole terminal strip may be necessary. For this configuration, run the low voltage wires behind the chassis to the right side of the console unit for termination to the terminal strip.

17. **Thermostat Location.** Location of the thermostat or zone sensor is an important element of effective room zone control. Areas where the thermostat/zone sensor should not be mounted include: behind doors or corners; near hot or cold air ducts; near radiant heat (heat emitted from appliances or sun); near concealed pipes or chimneys; on outside walls or other non conditioned surfaces; in air-flows from adjacent zones or other units.



18. **Unit Mounted Controls (Option).** For units with unit mounted controls, all low voltage connections are factory made. The fan will run continuous with unit mounted controls.

19. **Receptacle Plug (Option).** For units with the factory provided receptacle box options, the receptacle plug may now be connected to the electrical outlet.





# Performance Data

## Operating Pressures

GENERAL: There are many variables (airflow, air temperatures) in an air conditioning system that affect operating refrigerant pressures and temperatures. The charts below shows approximate conditions and is based on air flow at the rated SCFM, entering air at 80.6°F(DB), 66.2°F(WB) in cooling, 68°F(DB) in heating. (+)Heating data with 35°F EWT is based on the use of an anti-freeze solution having a freezing point 20°F lower than the minimum expected entering temperature.

**Table 4. Operating pressures in cooling/heating for unit sizes 006–018**

Operating Data										
Model GECE	Entering Water Temp, °F	Water Flow GPM	Cooling				Heating			
			Suction Pressure, PSIG	Discharge Pressure, PSIG	Water Temp Rise °F	Air Temp Drop °F DB	Suction Pressure PSIG	Discharge Pressure, PSIG	Water Temp Drop °F	Air Temp Rise °F DB
006 (60 Hz)	35°	1.4	—	—	—	—	91-105	255-325	10-13	21-26
006 (60 Hz)	35°	1.8	—	—	—	—	92-106	255-325	8-10	21-27
006 (60 Hz)	45°	1.4	142-164	188-239	12-16	23-29	107-123	267-339	11-14	24-30
006 (60 Hz)	45°	1.8	142-163	179-228	10-12	23-29	110-126	269-342	9-12	24-31
006 (60 Hz)	55°	1.4	144-165	217-276	12-15	23-29	124-143	279-355	12-16	27-34
006 (60 Hz)	55°	1.8	143-165	207-263	9-12	23-29	128-147	282-359	10-13	27-35
006 (60 Hz)	68°	1.4	146-168	259-329	12-15	22-28	149-172	297-378	14-18	31-39
006 (60 Hz)	68°	1.8	145-167	247-314	9-12	22-28	154-177	300-382	11-14	32-40
006 (60 Hz)	75°	1.4	147-169	280-357	11-15	21-27	164-189	307-391	15-19	33-42
006 (60 Hz)	75°	1.8	147-169	271-345	9-12	21-27	170-196	310-395	12-15	34-43
006 (60 Hz)	86°	1.4	147-170	331-422	12-15	20-26	190-219	323-411	16-21	36-46
006 (60 Hz)	86°	1.8	147-169	321-409	9-12	20-26	197-227	327-417	13-17	37-47
006 (60 Hz)	95°	1.4	148-170	392-498	12-15	19-24	—	—	—	—
006 (60 Hz)	95°	1.8	148-170	379-483	9-12	19-25	—	—	—	—
009 (60 Hz) 006 (50 Hz)	35°	1.7	—	—	—	—	93-107	258-328	10-12	21-26
009 (60 Hz) 006 (50 Hz)	35°	2.1	—	—	—	—	93-107	258-329	8-10	21-27
009 (60 Hz) 006 (50 Hz)	45°	1.7	149-171	189-241	13-16	23-29	108-125	271-344	11-14	24-30
009 (60 Hz) 006 (50 Hz)	45°	2.1	146-168	183-233	10-13	23-29	111-128	273-347	9-11	24-31
009 (60 Hz) 006 (50 Hz)	55°	1.7	144-166	216-275	12-15	23-29	126-145	284-362	12-15	27-34
009 (60 Hz) 006 (50 Hz)	55°	2.1	145-167	210-267	10-12	23-29	129-149	287-365	10-13	27-35
009 (60 Hz) 006 (50 Hz)	68°	1.7	146-169	254-323	11-14	22-28	152-175	303-386	14-17	31-39
009 (60 Hz) 006 (50 Hz)	68°	2.1	146-168	247-315	9-12	22-28	157-180	306-390	11-14	32-40
009 (60 Hz) 006 (50 Hz)	75°	1.7	146-168	280-356	11-14	21-27	167-193	313-399	14-18	33-42
009 (60 Hz) 006 (50 Hz)	75°	2.1	146-168	270-344	9-11	21-27	173-199	317-403	12-15	34-43
009 (60 Hz) 006 (50 Hz)	86°	1.7	146-168	333-424	11-14	20-26	194-224	330-420	16-20	36-46

continued on next page



**Table 4. Operating pressures in cooling/heating for unit sizes 006–018 (continued)**

Operating Data										
Model GECE	Entering Water Temp, °F	Water Flow GPM	Cooling				Heating			
			Suction Pressure, PSIG	Discharge Pressure, PSIG	Water Temp Rise °F	Air Temp Drop °F DB	Suction Pressure PSIG	Discharge Pressure, PSIG	Water Temp Drop °F	Air Temp Rise °F DB
009 (60 Hz) 006 (50 Hz)	86°	2.1	147-169	321-409	9-12	20-26	201-232	334-425	13-16	37-47
009 (60 Hz) 006 (50 Hz)	95°	1.7	147-169	396-504	12-15	19-24	—	—	—	—
009 (60 Hz) 006 (50 Hz)	95°	2.1	146-168	381-485	9-12	19-25	—	—	—	—
012 (60 Hz) 009 (50 Hz)	35°	2.2	—	—	—	—	92-106	276-351	10-12	21-26
012 (60 Hz) 009 (50 Hz)	35°	2.8	—	—	—	—	93-106	276-352	8-10	21-27
012 (60 Hz) 009 (50 Hz)	45°	2.2	143-164	180-229	12-15	23-29	108-124	289-367	11-14	24-30
012 (60 Hz) 009 (50 Hz)	45°	2.8	143-164	173-220	9-12	23-29	110-127	290-370	9-11	24-31
012 (60 Hz) 009 (50 Hz)	55°	2.2	144-166	208-264	11-15	23-29	125-144	302-385	12-15	27-34
012 (60 Hz) 009 (50 Hz)	55°	2.8	144-166	200-254	9-11	23-29	128-148	305-388	10-12	27-35
012 (60 Hz) 009 (50 Hz)	68°	2.2	146-168	247-315	11-14	22-28	152-175	322-409	13-17	31-39
012 (60 Hz) 009 (50 Hz)	68°	2.8	146-168	240-305	9-11	22-28	156-179	324-413	11-14	32-40
012 (60 Hz) 009 (50 Hz)	75°	2.2	147-169	273-347	11-14	21-27	168-193	333-423	14-18	33-42
012 (60 Hz) 009 (50 Hz)	75°	2.8	147-169	265-337	9-11	21-27	172-198	336-427	11-15	34-43
012 (60 Hz) 009 (50 Hz)	86°	2.2	147-169	323-411	11-14	20-26	195-224	350-446	15-20	36-46
012 (60 Hz) 009 (50 Hz)	86°	2.8	147-169	314-399	9-11	20-26	201-231	354-450	12-16	37-47
012 (60 Hz) 009 (50 Hz)	95°	2.2	148-170	377-480	11-15	19-24	—	—	—	—
012 (60 Hz) 009 (50 Hz)	95°	2.8	148-170	367-467	9-12	19-25	—	—	—	—
015 (60 Hz) 012 (50 Hz)	35°	2.8	—	—	—	—	90-103	265-337	10-12	21-26
015 (60 Hz) 012 (50 Hz)	35°	3.5	—	—	—	—	91-104	266-338	8-10	21-27
015 (60 Hz) 012 (50 Hz)	45°	2.8	144-165	178-227	11-14	23-29	105-121	277-353	11-14	24-30
015 (60 Hz) 012 (50 Hz)	45°	3.5	144-165	172-219	9-12	23-29	108-124	279-355	9-11	24-31
015 (60 Hz) 012 (50 Hz)	55°	2.8	145-167	206-262	11-14	23-29	123-141	290-369	12-15	27-34
015 (60 Hz) 012 (50 Hz)	55°	3.5	145-166	200-254	9-12	23-29	126-145	292-372	10-12	27-35
015 (60 Hz) 012 (50 Hz)	68°	2.8	146-168	247-314	11-14	22-28	149-171	308-392	13-17	31-39

continued on next page



## Performance Data

**Table 4. Operating pressures in cooling/heating for unit sizes 006–018 (continued)**

Model GECE	Entering Water Temp, °F	Water Flow GPM	Operating Data							
			Cooling				Heating			
			Suction Pressure, PSIG	Discharge Pressure, PSIG	Water Temp Rise °F	Air Temp Drop °F DB	Suction Pressure PSIG	Discharge Pressure, PSIG	Water Temp Drop °F	Air Temp Rise °F DB
015 (60 Hz) 012 (50 Hz)	68°	3.5	146-168	239-305	9-11	22-28	152-175	311-396	11-14	32-40
015 (60 Hz) 012 (50 Hz)	75°	2.8	147-169	272-346	11-14	21-27	164-188	318-405	14-18	33-42
015 (60 Hz) 012 (50 Hz)	75°	3.5	147-169	264-336	9-11	21-27	169-194	320-408	11-14	34-43
015 (60 Hz) 012 (50 Hz)	86°	2.8	148-170	321-408	11-15	20-26	191-220	334-424	15-19	36-46
015 (60 Hz) 012 (50 Hz)	86°	3.5	148-170	311-396	9-12	20-26	197-226	337-429	12-15	37-47
015 (60 Hz) 012 (50 Hz)	95°	2.8	148-171	370-471	12-15	19-24	—	—	—	—
015 (60 Hz) 012 (50 Hz)	95°	3.5	148-171	361-460	9-12	19-25	—	—	—	—
018 (60 Hz) 015 (50 Hz)	35°	3.4	—	—	—	—	92-106	274-349	9-12	21-26
018 (60 Hz) 015 (50 Hz)	35°	4.2	—	—	—	—	92-106	274-349	7-9	21-27
018 (60 Hz) 015 (50 Hz)	45°	3.4	141-162	178-226	11-14	23-29	108-124	288-367	10-13	24-30
018 (60 Hz) 015 (50 Hz)	45°	4.2	141-162	172-219	9-11	23-29	110-127	289-368	8-11	24-31
018 (60 Hz) 015 (50 Hz)	55°	3.4	141-163	206-262	11-14	23-29	126-145	302-385	11-14	27-34
018 (60 Hz) 015 (50 Hz)	55°	4.2	141-162	200-254	9-11	23-29	129-148	305-388	9-12	27-35
018 (60 Hz) 015 (50 Hz)	68°	3.4	143-164	249-317	11-14	22-28	152-175	325-413	13-16	31-39
018 (60 Hz) 015 (50 Hz)	68°	4.2	143-164	242-308	9-11	22-28	156-180	326-415	10-13	32-40
018 (60 Hz) 015 (50 Hz)	75°	3.4	143-165	275-350	11-14	21-27	169-194	336-428	13-17	33-42
018 (60 Hz) 015 (50 Hz)	75°	4.2	143-165	267-340	9-11	21-27	173-199	339-432	11-14	34-43
018 (60 Hz) 015 (50 Hz)	86°	3.4	145-167	320-407	11-14	20-26	196-225	357-454	15-19	36-46
018 (60 Hz) 015 (50 Hz)	86°	4.2	145-167	312-397	9-11	20-26	202-232	360-458	12-15	37-47
018 (60 Hz) 015 (50 Hz)	95°	3.4	146-168	362-461	11-14	19-24	—	—	—	—
018 (60 Hz) 015 (50 Hz)	95°	4.2	146-168	353-450	9-11	19-25	—	—	—	—

## Water Pressure Drop

Table 5, p. 27 should be used to define feet of head/pressure drop. Please note the feet of pressure (ft/head) provided is at ARI/ISO standard.

**Note:** To calculate feet of head, when using gauges that read in PSIG, multiply PSI by 2.31.

**Table 5. Water pressure drops**

Cooling WPD in feet of head					Heating WPD in feet of head				
Unit Size 60 Hz	Unit Size 50 Hz	EWT F	GPM	Ft. Pressure	Unit Size 60 Hz	Unit Size 50 Hz	EWT F	GPM	Ft. Pressure
006	—	86	1.8	3.6	006	—	68	1.8	4.3
009	006	86	2.1	4.3	009	006	68	2.1	5.0
012	009	86	2.8	9.3	012	009	68	2.8	10.7
015	012	86	3.5	13.1	015	012	68	3.5	14.9
018	015	86	4.2	9.1	018	015	68	4.2	10.2

## Water Volume

Table 6 is provided for use in calculating glycol requirements for the unit.

**Table 6. Water volume**

Unit Size 60 Hz	Unit Size 50 Hz	Water side Volume Cubic In.	Water side Volume Cubic Ft.	WaterSide Volume Gallons
006-009	006	13.6	0.008	0.059
012-15	009-12	23.1	0.013	0.100
018	015	36	0.021	0.156



# Electrical Data

Table 7. GECE electrical data

Model No.	Unit Volts	Total Unit FLA	Comp. RLA (ea)	Comp. LRA (ea)	No. of Comp.	Cmp MCC	Blower Motor FLA	Blower Motor hP	Fan Motor Num.	Minimum Circuit Ampacity	Maximum Overcurrent Protective Device	Electric Heat		
												Size	kW	Amps
006	115/60/1	6.5	5.6	30.0	1	7.5	0.90	1/20	1	7.9	15	None	0	0
006	208/60/1	4.1	3.3	14.0	1	4.2	0.80	1/20	1	4.9	15	None	0	0
006	208/60/1	11.6	3.3	14.0	1	4.2	0.80	1/20	1	14.5	15	Min	2.25	10.82
006	208/60/1	15.2	3.3	14.0	1	4.2	0.80	1/20	1	19.0	20	Max	3	14.42
006	230/60/1	3.9	3.2	15.0	1	4.2	0.70	1/20	1	4.7	15	None	0	0
006	230/60/1	13.2	3.2	15.0	1	4.2	0.70	1/20	1	16.5	20	Min	3	12.5
006	220-240/50/1	3.6	2.9	17.0	1	4.0	0.70	1/20	1	4.3	15	None	0	0
006	220-240/50/1	13.2	2.9	17.0	1	4.0	0.70	1/20	1	16.5	20	Min	3	12.5
006	265/60/1	3.2	2.5	11.0	1	3.5	0.70	1/20	1	3.8	15	None	0	0
006	265/60/1	11.5	2.5	11.0	1	3.5	0.70	1/20	1	14.4	15	Min	3	10.83
009	115/60/1	7.3	6.4	36.0	1	8.6	0.90	1/20	1	8.9	15	None	0	0
009	208/60/1	4.5	3.7	16.0	1	4.8	0.80	1/20	1	5.4	15	None	0	0
009	208/60/1	11.6	3.7	16.0	1	4.8	0.80	1/20	1	14.5	15	Min	2.25	10.82
009	208/60/1	15.2	3.7	16.0	1	4.8	0.80	1/20	1	19.0	20	Max	3	14.42
009	230/60/1	4.2	3.5	17.0	1	4.8	0.70	1/20	1	5.1	15	None	0	0
009	230/60/1	13.2	3.5	17.0	1	4.8	0.70	1/20	1	16.5	20	Min	3	12.5
009	230/60/1	17.4	3.5	17.0	1	4.8	0.70	1/20	1	21.7	25	Max	4	16.67
009	220-240/50/1	6.0	5.3	23.0	1	7.4	0.70	1/12	1	7.3	15	None	0	0
009	220-240/50/1	13.2	5.3	23.0	1	7.4	0.70	1/12	1	16.5	20	Min	3	12.5
009	220-240/50/1	17.4	5.3	23.0	1	7.4	0.70	1/12	1	21.7	25	Max	4	16.67
009	265/60/1	3.5	2.8	13.0	1	3.7	0.70	1/20	1	4.2	15	None	0	0
009	265/60/1	11.5	2.8	13.0	1	3.7	0.70	1/20	1	14.4	15	Min	3	10.83
009	265/60/1	15.1	2.8	13.0	1	3.7	0.70	1/20	1	18.9	20	Max	4	14.44
012	115/60/1	13.3	12.1	58.0	1	16.9	1.20	1/12	1	16.3	20	None	0	0
012	208/60/1	7.2	6.3	30.0	1	8.8	0.90	1/12	1	8.8	15	None	0	0
012	208/60/1	11.7	6.3	30.0	1	8.8	0.90	1/12	1	14.7	15	Min	2.25	10.82
012	208/60/1	15.3	6.3	30.0	1	8.8	0.90	1/12	1	19.2	20	Max	3	14.42
012	230/60/1	7.0	6.3	30.0	1	8.8	0.70	1/12	1	8.6	15	None	0	0
012	230/60/1	13.2	6.3	30.0	1	8.8	0.70	1/12	1	16.5	20	Min	3	12.5
012	230/60/1	17.4	6.3	30.0	1	8.8	0.70	1/12	1	21.7	25	Max	4	16.67
012	220-240/50/1	7.4	6.7	30.0	1	9.4	0.70	1/12	1	9.1	15	None	0	0
012	220-240/50/1	13.2	6.7	30.0	1	9.4	0.70	1/12	1	16.5	20	Min	3	12.5
012	220-240/50/1	17.4	6.7	30.0	1	9.4	0.70	1/12	1	21.7	25	Max	4	16.67
012	265/60/1	5.7	5.0	23.0	1	7.0	0.70	1/12	1	7.0	15	None	0	0
012	265/60/1	11.5	5.0	23.0	1	7.0	0.70	1/12	1	14.4	15	Min	3	10.83
012	265/60/1	15.1	5.0	23.0	1	7.0	0.70	1/12	1	18.9	20	Max	4	14.44
015	115/60/1	16.1	14.9	60.0	1	20.9	1.20	1/12	1	19.8	20	None	0	0
015	208/60/1	8.9	7.9	36.0	1	11.1	1.00	1/12	1	10.9	15	None	0	0
015	208/60/1	11.8	7.9	36.0	1	11.1	1.00	1/12	1	14.8	15	Min	2.25	10.82
015	208/60/1	15.4	7.9	36.0	1	11.1	1.00	1/12	1	19.3	20	Max	3	14.42

continued on next page

**Table 7. GECE electrical data (continued)**

Model No.	Unit Volts	Total Unit FLA	Comp. RLA (ea)	Comp. LRA (ea)	No. of Comp.	Cmp MCC	Blower Motor FLA	Blower Motor hP	Fan Motor Num.	Minimum Circuit Ampacity	Maximum Overcurrent Protective Device	Electric Heat		
												Size	kW	Amps
015	230/60/1	8.8	7.9	36.0	1	11.1	0.90	1/12	1	10.8	15	None	0	0
015	230/60/1	13.4	7.9	36.0	1	11.1	0.90	1/12	1	16.8	20	Min	3	12.5
015	230/60/1	17.6	7.9	36.0	1	11.1	0.90	1/12	1	22.0	25	Max	4	16.67
015	220-240/50/1	8.6	7.9	28.0	1	11.1	0.70	1/12	1	10.6	15	None	0	0
015	220-240/50/1	13.2	7.9	28.0	1	11.1	0.70	1/6	1	16.5	20	Min	3	12.5
015	220-240/50/1	17.4	7.9	28.0	1	11.1	0.70	1/6	1	21.7	25	Max	4	16.67
015	265/60/1	7.1	6.4	30.0	1	9.0	0.70	1/6	1	8.7	15	None	0	0
015	265/60/1	11.5	6.4	30.0	1	9.0	0.70	1/12	1	14.4	15	Min	3	10.83
015	265/60/1	15.1	6.4	30.0	1	9.0	0.70	1/12	1	18.9	20	Max	4	14.44
018	208/60/1	10.0	9.0	30.0	1	12.6	1.00	1/6	1	12.3	15	None	0	0
018	208/60/1	11.8	9.0	30.0	1	12.6	1.00	1/6	1	14.8	15	Min	2.25	10.82
018	208/60/1	15.4	9.0	30.0	1	12.6	1.00	1/6	1	19.3	20	Max	3	14.42
018	230/60/1	9.9	9.0	30.0	1	12.6	0.90	1/6	1	12.2	15	None	0	0
018	230/60/1	13.4	9.0	30.0	1	12.6	0.90	1/6	1	16.8	20	Min	3	12.5
018	230/60/1	17.6	9.0	30.0	1	12.6	0.90	1/6	1	22.0	25	Max	4	16.67
018	265/60/1	8.5	7.8	30.0	1	10.9	0.70	1/6	1	10.5	15	None	0	0
018	265/60/1	11.5	7.8	30.0	1	10.9	0.70	1/6	1	14.4	15	Min	3	10.83
018	265/60/1	15.1	7.8	30.0	1	10.9	0.70	1/6	1	18.9	20	Max	4	14.44



# Pre-Start

## Pre-Startup Checklist

Before energizing the unit, the following system devices must be checked:

- Is the high voltage power supply correct and in accordance with the nameplate ratings?
- Is the field wiring and circuit protection the correct size?
- Is the low voltage control circuit wiring correct per the unit wiring diagram?
- Is the piping system clean/complete and correct? (A recommendation of all system flushing of debris from the water-to-refrigerant heat exchanger, along with air purging from the water-to-refrigerant heat exchanger be done in accordance with the Closed-Loop/Ground Source Heat Pump Systems Installation Guide).
- Is vibration isolation provided? (i.e. unit isolation pad, hose kits)
- Is unit serviceable? (Allow a 12" clearance at the unit front for serviceability).
- Are the low/high-side pressure temperature caps secure and in place?
- Are all the unit access panels secure and in place?
- Is the thermostat in the OFF position?
- Is the water flow established and circulating through all the units?
- Is the duct work correctly sized, run, taped, insulated and weather proofed with proper unit arrangement?
- Is the condensate line properly sized, run, and pitched?
- Is the zone sensor (when used) correctly wired and in a good location?
- Does the indoor blower turn freely without rubbing?
- Has all work been done in accordance with applicable local and national codes?
- Has heat transfer fluid been added in the proper mix to prevent freezing in closed system application?



# Start-Up

## Initial Unit Start-up

**Note:** Start-up for the Tracer™ ZN510 Controller may be found in WSHP-IOP-2. Start-up for wall-mounted thermostats found in thermostat manufacturer literature.

Start-up with the conventional thermostat is included below:

1. Set the thermostat to the highest position.
2. Set the thermostat system switch to COOL with the fan control to AUTO. The compressor should NOT run.
3. Reduce the thermostat setting until the compressor, reversing valve and isolation valve (if used) are energized. Adjust water flow utilizing pressure/temperature plugs and comparing to tables contained in specification sheet data. Water leaving the heat exchanger should be warmer than the entering water temperature (approximately 9-12°F); blower operation should be smooth; compressor and blower amps should be within data plate ratings; the suction line should be cool with no frost observed in the refrigerant circuit.
4. Check the cooling refrigerant pressures against values in [Table 4, p. 24](#).
5. Turn the thermostat system switch to the OFF position. Unit should stop running and the reversing valve should de-energize.
6. Leave unit off for approximately FIVE minutes to allow for pressure equalization.
7. Turn the thermostat to the lowest setting.
8. Set the thermostat system switch to the HEAT position.
9. Adjust the temperature setting upward until the unit is energized. Warm air should blow from the register. A water temperature decrease of approximately 5-9°F leaving the heat exchanger should be noted. The blower and compressor operation should be smooth with no frost observed in the refrigeration circuit.
10. Check the heating refrigerant pressures against values in [Table 4, p. 24](#).
11. Set the thermostat to maintain the desired space temperature.
12. Instruct the owner on system operation.

**Installing Contractor:** Use this form to thoroughly check-out the system and units before and during start-up. (This form need not be returned to the factory unless requested during technical service support).

Job Name:	
Model Number:	
Date:	
Serial Number:	

In order to minimize troubleshooting and costly system failures, complete the following checks and data entries before the system is put into full operation.

MODE	Heat	Cool
Entering fluid temperature		
Leaving fluid temperature		
Temperature differential		
Return-air temperature DB/WB		
Supply-air temperature DB/WB		
Temperature differential		
Water coil heat exchanger (Water Pressure IN)		



## Start-Up

---

MODE	Heat	Cool
Water coil heat exchanger (Water Pressure OUT)		
Pressure Differential		
COMPRESSOR		
Amps		
Volts		
Discharge line temperature (after 10 minutes)		



# Maintenance

## Preventive Maintenance

Maintenance on the unit is simplified with the following preventive suggestions:

Filter maintenance must be performed to assure proper operation of the equipment. Filters should be inspected. Filter sizing includes:

Unit Size 50/60 Hz	Filter Size nominal inch
006-018	10 x 32 3/8 (std height unit)
006-018	7 3/4 x 30 5/8 (low height unit)

Check the contactors and relays within the control panel at least once a year. It is good practice to check the tightness of the various wiring connections within the control panel.

A strainer (60 mesh or greater) must be used on an open loop system to keep debris from entering the unit heat exchanger and to ensure a clean system.

For units on well water, it is important to check the cleanliness of the water-to-refrigerant heat exchanger. Should it become contaminated with dirt and scaling as a result of bad water, the heat exchanger will have to be back flushed and cleaned to remove the scale. This service should be performed by an experienced service person. If bad water is discovered, consult with a water treatment expert.

It should be noted that the water quality should be checked periodically. (See [Table 8, p. 33](#)).

**Table 8. Water quality**

Scaling	
Calcium and magnesium (total hardness)	Less than 350 ppm
Corrosion	
pH	7-9.5
Hydrogen Sulfide	Less than 1 ppm
Sulfates	Less than 25 ppm
Chlorides	Less than 125 ppm
Carbon Dioxide	Less than 75 ppm
Total dissolved solids (TDS)	Less than 1000 ppm
Biological Growth	
Iron Bacteria	Low
Erosion	
Suspended Solids	Low

## Filter Replacement (standard height configuration)

Filter replacement is done at the front return-air opening of the console unit. No tools are required for the replacement. The maintenance process is done via a 3-STEP process.

1. Through the return-air opening, slide filter to the back of the console unit.
2. Allow the front edge of the filter to drop to floor level.
3. Pull the filter out of the front opening.

**Note:** REVERSE the cycle to install a new filter.

### **Filter Replacement (low height configuration)**

Filter replacement is done at the front return-air opening of the console unit. A slotted screw driver is needed for the replacement. The maintenance process is done via a 2-STEP process.

1. Insert screw-driver and depress grill tab (2-per grille). Rotate grille down, and lift grille upward to remove grille.
2. Remove the filter through the grille hole in the cabinet front panel.

**Note:** *REVERSE the cycle to install a new filter.*

# Troubleshooting

Problem	Heating	Cooling	Cause	Correction
<b>No response to any thermostat setting</b>	X	X	Main power off	Check fuses
	X	X	Defective control transformer	Replace
	X	X	Broken or loose connection	Repair
	X	X	Defective thermostat	Replace
	X	X	Transformer	Reset Transformer
<b>Unit short cycles</b>	X	X	Thermostat or sensor improperly located	Relocate
	X	X	Unit contains unit mounted thermostat	Change jumper on thermostat from 2-degrees to 4-degrees
<b>Blower runs, but compressor does not</b>	X	X	Defective compressor overload	Replace (if external)
	X	X	Defective compressor contactor	Replace
	X	X	Supply Voltage too low	Correct
	X	X	Defective compressor capacitor	Replace
	X	X	Defective windings	Replace
	X	X	Limit switches open	Check cause/Replace or repair
<b>Insufficient capacity</b>	X	X	Dirty filter	Replace/clean
	X	X	Blower RPM too low	Correct
	X	X	Loss of conditioned air due to leaks in ductwork	Repair leaks
		X	Introduction of excessively hot return-air	Correct
	X		Introduction of excessively cold return-air	Correct
	X	X	Low on refrigerant charge	Locate leak, repair and recharge by weight (not by superheat)
	X	X	Restricted thermal expansion valve	Replace
	X	X	Defective reversing valve	See WSHP-IOM-# for touch test chart
	X	X	Thermostat improperly located	Relocate
	X	X	Unit undersized	Recalculate heat gains/losses
	X	X	Inadequate water flow	Increase GPM
	X	X	Scaling in heat exchanger	Clean or replace
		X	Water too hot	Decrease temperature
	X		Water too cold	Increase temperature
<b>High pressure switch</b>		X	Inadequate GPM	Increase water flow to unit
		X	Water too hot	Decrease temperature
	X		Inadequate air flow	Check, clean blower and coil
	X		Dirty filter	Clean/replace
	X	X	Overcharged with refrigerant	Decrease charge
	X	X	Defective pressure switch	Check or replace
<b>High head pressure</b>		X	Trash in heat exchanger	Backflush
		X	Low water flow	Increase GPM
	X	X	Overcharge of refrigerant	Decrease charge
	X	X	Non-condensable in system	Evacuate and recharge by weight
	X	X	Water too hot	Decrease temperature
	X		Dirty filter	Clean / replace
	X		Inadequate air flow	Check, clean blower and coil
<b>Low suction pressure</b>	X	X	Undercharged	Locate leak, repair and recharge
	X	X	Restricted thermal expansion valve	Repair / replace
		X	Inadequate air flow	Check, clean blower and coil
		X	Dirty filter	Clean/replace
	X		Inadequate GPM	Increase GPM
<b>Low Pressure switch open</b>	X		Inadequate GPM	Increase GPM
	X		Water too cold	Increase temperature
		X	Inadequate air flow	Increase CFM
		X	Dirty filter	Clean/replace
	X	X	Undercharged with refrigerant	Increase charge
	X	X	Defective pressure switch	Replace
	X	X	Heat transfer fluid too cold	Raise water temperature

## Troubleshooting

---

### Deluxe Controls

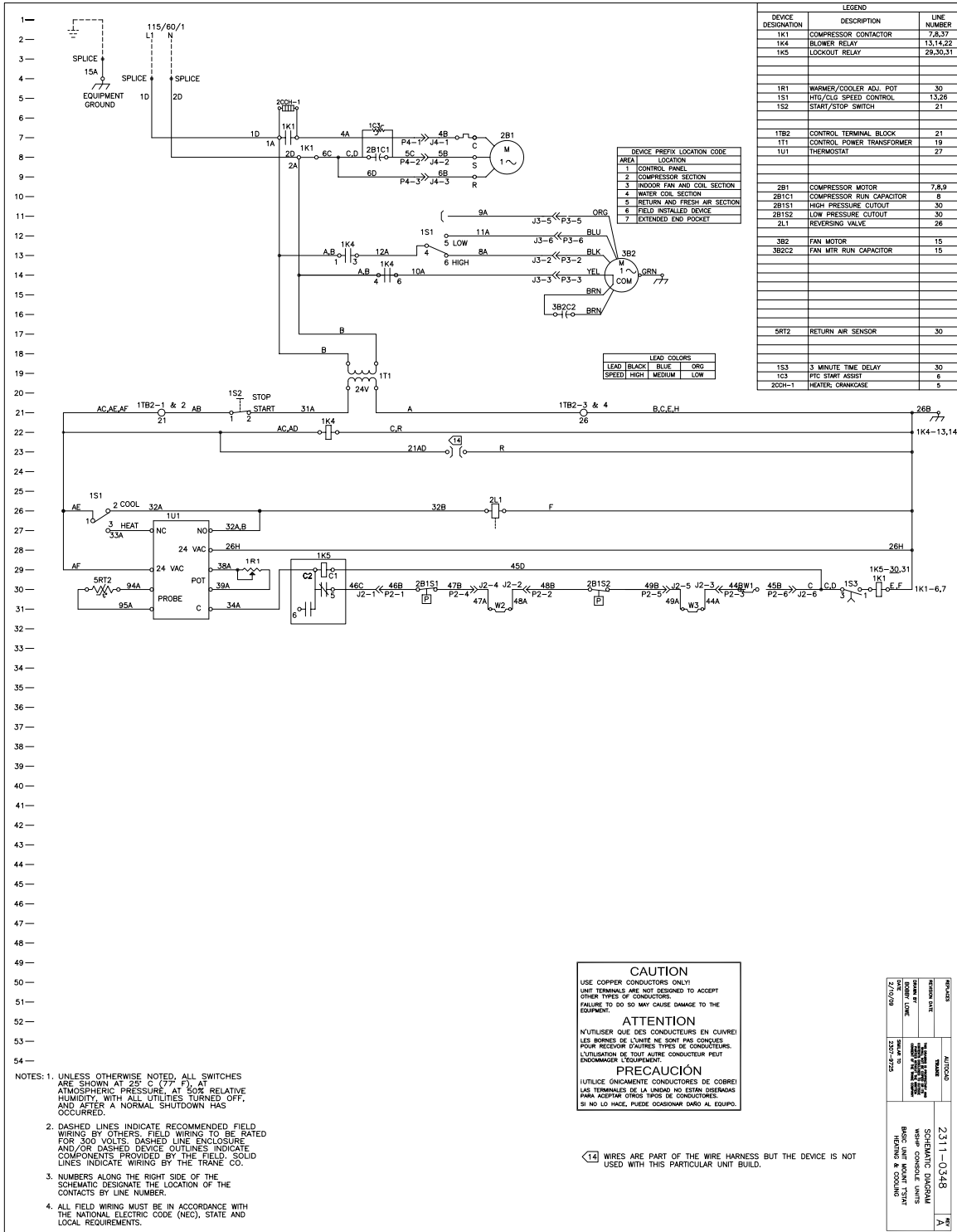
Troubleshooting equipment containing the Deluxe Control option may be made easy by using the three light emitting diodes (LEDs). These LEDs are provided for indicating the operating mode of the controller. The LEDs are intended to aid in troubleshooting and unit maintenance. They are labeled on the circuit board with numbers as referenced in [Table 9, p. 36](#).

**Table 9. Diagnostic LED's**

Color: Green	Color: Red		Controller Mode
LED1	LED2	LED3	
OFF	OFF	OFF	Control OFF
ON	OFF	OFF	Normal/Compressor OFF
ON	OFF	FLASH	Anti-short cycle
ON	OFF	ON	Normal/Compressor ON
FLASH	ON	OFF	Brownout condition
ON	FLASH	ON	Soft Lockout (low pressure)
ON	FLASH	FLASH	Soft Lockout (high pressure)
ON	ON	ON	Manual Lockout (low pressure)
ON	ON	FLASH	Manual Lockout (high pressure)
ON	FLASH	OFF	Manual Lockout (condensate overflow)
ON	ON	OFF	Compressor Disable

# Unit Wiring

Figure 15. Basic 115V/60Hz/1Ph



# Unit Wiring

Figure 16. Basic 220-240V/50Hz/1Ph

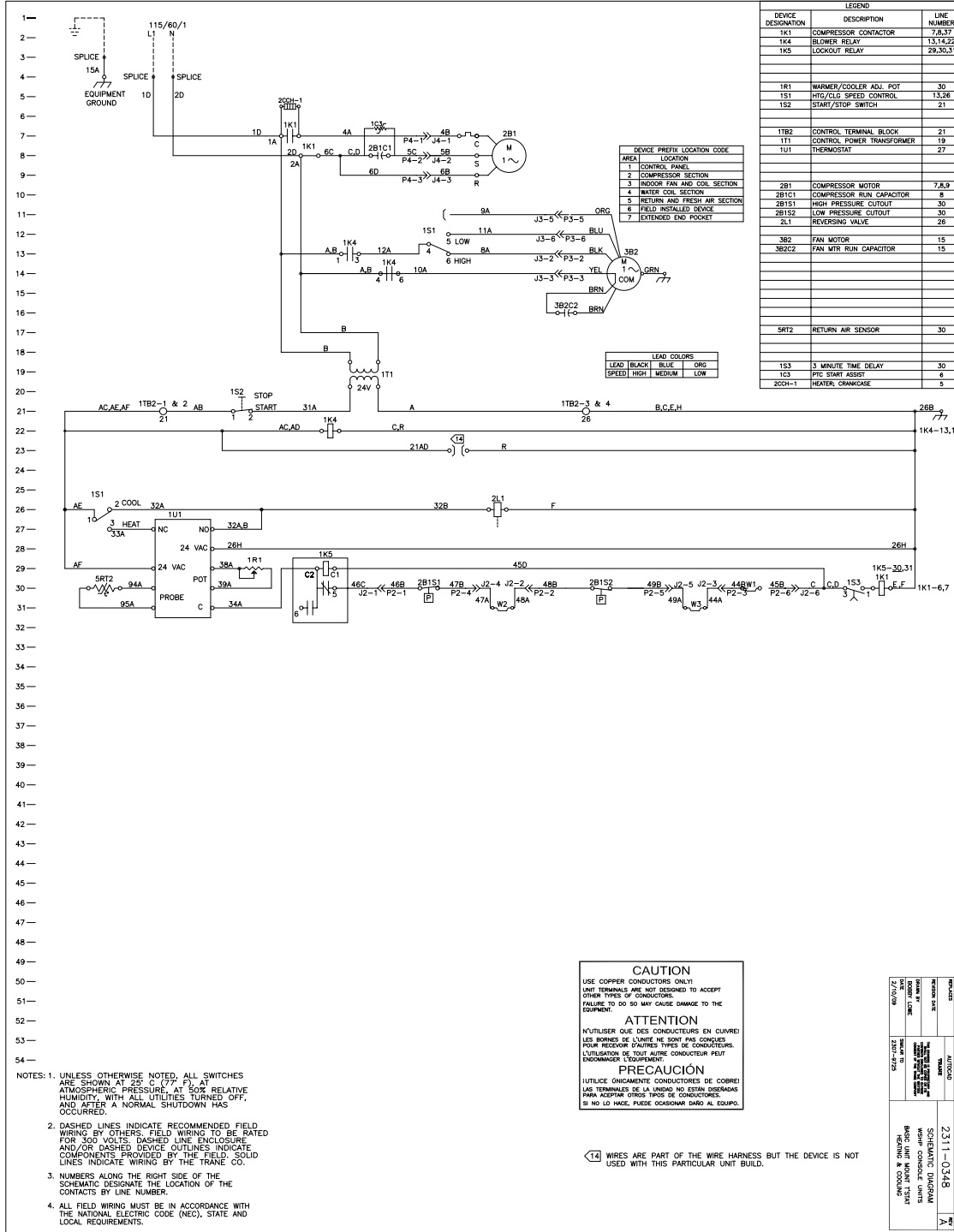


Figure 17. Deluxe 230V/60Hz/1PH

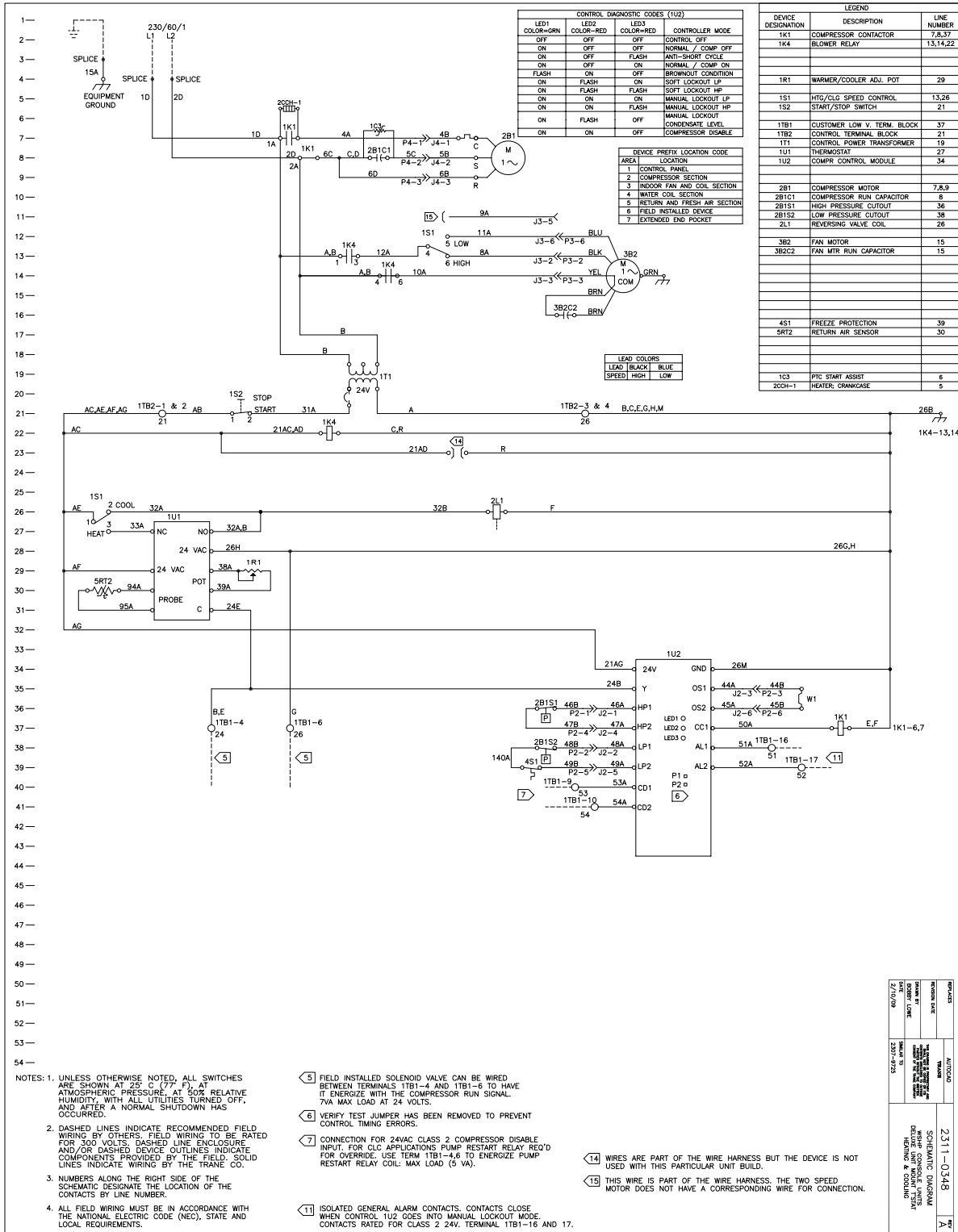
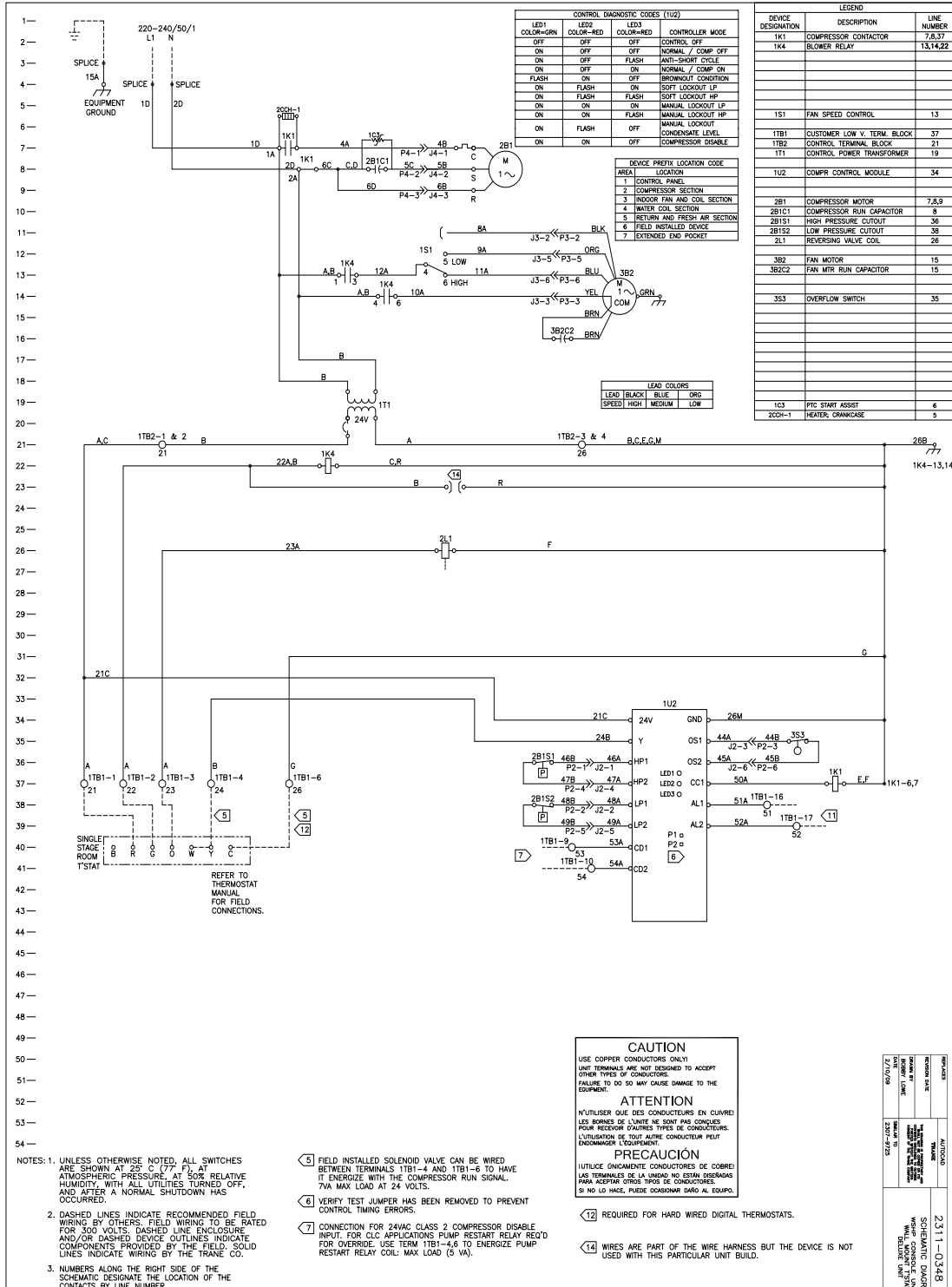


Figure 18. Deluxe 220-240V/50Hz/1Ph



NOTES: 1. UNLESS OTHERWISE NOTED, ALL SWITCHES ARE SHOWN AT 25 (77 F.) AT ATMOSPHERIC PRESSURE, AT 50% RELATIVE HUMIDITY, WITH ALL UTILITIES TURNED OFF, AND AFTER A NORMAL SHUTDOWN HAS OCCURRED.

2. DASHED LINES INDICATE RECOMMENDED FIELD WIRING BY OTHERS. FIELD WIRING TO BE RATED FOR 300 VOLTS. DASHED LINE ENCLOSURE AND/OR DASHED DEVICE OUTLINES INDICATE COMPONENTS PROVIDED BY THE FIELD. SOLID LINES INDICATE WIRING BY THE TRANE CO.

3. NUMBERS ALONG THE RIGHT SIDE OF THE SCHEMATIC DESIGNATE THE LOCATION OF THE CONTACTS BY LINE NUMBER

- 5 FIELD INSTALLED SOLENOID VALVE CAN BE WIRED BETWEEN TERMINALS 1T1B1-4 AND 1T1B1-6 TO HAVE IT ENERGIZE WITH THE COMPRESSOR RUN SIGNAL. 7VA MAX LOAD AT 24 VOLTS.
- 6 VERIFY TEST JUMPER HAS BEEN REMOVED TO PREVENT CONTROL TIMING ERRORS.
- 7 CONNECTION FOR 24VAC CLASS 2 COMPRESSOR DISABLE INPUT. FOR CLC APPLICATIONS PUMP RESTART RELAY REED FOR OVERRIDE. USE TERM 1T1B1-4,6 TO ENERGIZE PUMP RESTART RELAY COIL. MAX LOAD (5 VA).

**CAUTION**  
USE COPPER CONDUCTORS ONLY!  
UNIT TERMINALS ARE NOT DESIGNED TO ACCEPT OTHER TYPES OF CONDUCTORS.  
FAILURE TO DO SO MAY CAUSE DAMAGE TO THE EQUIPMENT.

**ATTENTION**  
N'UTILISER QUE DES CONDUCTEURS EN CUIVRE  
LES BORNES DE L'UNITÉ NE SONT PAS CONÇUES POUR RECEVOIR D'AUTRES TYPES DE CONDUCTEURS.  
L'UTILISATION DE TOUT AUTRE CONDUCTEUR PEUT ENDOMMAGER L'ÉQUIPEMENT.

**PRECAUCIÓN**  
¡UTILICE ÚNICAMENTE CONDUCTORES DE COBRE!  
LAS TERMINALES DE LA UNIDAD NO ESTÁN DISEÑADAS PARA ACEPTAR OTROS TIPOS DE CONDUCTORES.  
SI NO LO HACE, PUEDE OCASIONAR DAÑO AL EQUIPO.

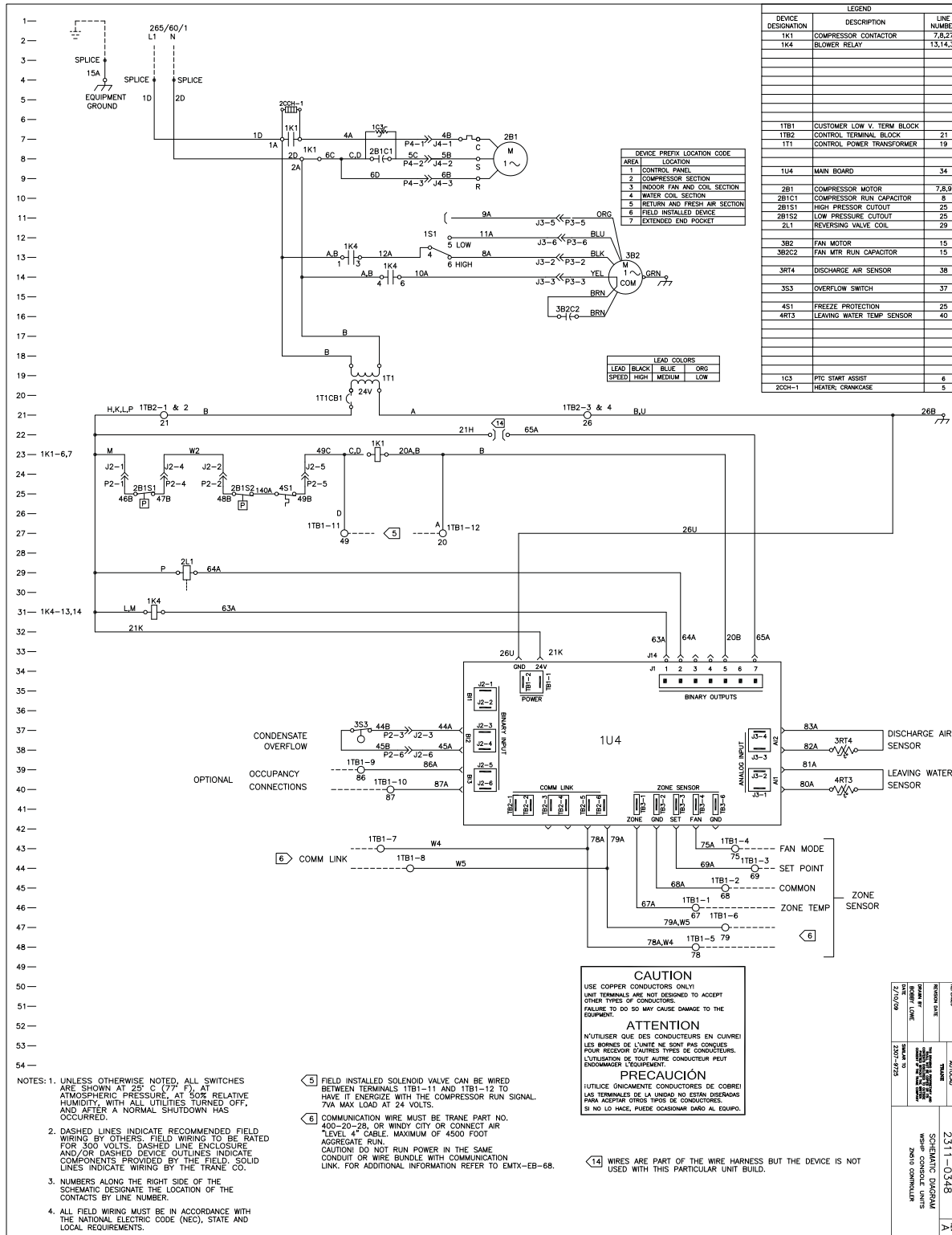
- 12 REQUIRED FOR HARD WIRED DIGITAL THERMOSTATS.
- 14 WIRES ARE PART OF THE WIRE HARNESS BUT THE DEVICE IS NOT USED WITH THIS PARTICULAR UNIT BUILD.

REVISION	DATE	BY	DESCRIPTION
1	02/01/09	...	...
2	03/27/12	...	...

2111-0348  
SCHEMATIC DIAGRAM  
WIRING CONNECTIONS  
REVISION 13



Figure 19. Tracer ZN510 265V/60Hz/1Ph



NOTES: 1. UNLESS OTHERWISE NOTED, ALL SWITCHES ARE SHOWN AT 25° C (77° F) AT ATMOSPHERIC PRESSURE, AT 50% RELATIVE HUMIDITY, WITH ALL UTILITIES TURNED OFF, AND AFTER A NORMAL SHUTDOWN HAS OCCURRED.

2. DASHED LINES INDICATE RECOMMENDED FIELD WIRING BY OTHERS; FIELD WIRING TO BE RATED FOR 300 VOLTS. DASHED LINE ENCLOSURE AND/OR DASHED DEVICE OUTLINES INDICATE COMPONENTS PROVIDED BY THE FIELD. SOLID LINES INDICATE WIRING BY THE TRANE CO.

3. NUMBERS ALONG THE RIGHT SIDE OF THE SCHEMATIC DESIGNATE THE LOCATION OF THE CONTACTS BY LINE NUMBER.

4. ALL FIELD WIRING MUST BE IN ACCORDANCE WITH THE NATIONAL ELECTRIC CODE (NEC), STATE AND LOCAL REQUIREMENTS.

5 FIELD INSTALLED SOLENOID VALVE CAN BE WIRED BETWEEN TERMINALS 1TB1-11 AND 1TB1-12 TO HAVE IT ENERGIZE WITH THE COMPRESSOR RUN SIGNAL. 7VA MAX LOAD AT 24 VOLTS.

6 COMMUNICATION WIRE MUST BE TRANE PART NO. 40D-20-28, OR WINDY CITY OR CONNECT AIR "LEVEL 4" CABLE. MAXIMUM OF 4500 FOOT AGGREGATE RUN. CAUTION! DO NOT RUN POWER IN THE SAME CONDUIT OR WIRE BUNDLE WITH COMMUNICATION LINK. FOR ADDITIONAL INFORMATION REFER TO EMTX-EB-68.

**CAUTION**  
USE COPPER CONDUCTORS ONLY!  
UNIT TERMINALS ARE NOT DESIGNED TO ACCEPT OTHER TYPES OF CONDUCTORS.  
FAILURE TO DO SO MAY CAUSE DAMAGE TO THE EQUIPMENT.

**ATTENTION**  
N'UTILISER QUE DES CONDUCTEURS EN CUIVRE!  
LES BORNES DE L'UNITÉ NE SONT PAS CONÇUES POUR RECEVOIR D'AUTRES TYPES DE CONDUCTEURS.  
L'UTILISATION DE TOUT AUTRE CONDUCTEUR PEUT ENDOMMAGER L'ÉQUIPEMENT.

**PRECAUCIÓN**  
UTILICE ÚNICAMENTE CONDUCTORES DE COBRE!  
LAS TERMINALES DE LA UNIDAD NO ESTÁN DISEÑADAS PARA ACEPTAR OTROS TIPOS DE CONDUCTORES.  
SI NO LO HACE, PUEDE OCASIONAR DAÑO AL EQUIPO.

14 WIRES ARE PART OF THE WIRE HARNESS BUT THE DEVICE IS NOT USED WITH THIS PARTICULAR UNIT BUILD.

DATE	2/10/09
REVISION	2311-0348
DESCRIPTION	SCHEMATIC DIAGRAM
BY	WSHP-CONSULE UNITS
CHECKED BY	ZN510 CONSULTANT





# Warranty

## Standard Warranty

The standard water-source heat pump warranty is Trane's parts-only warranty, running 12 months from startup, not to exceed 18-months from shipment.

## Extended Warranty

The optional extended warranty is a second through fifth year warranty. The time starts at the end of the standard 1-year coverage through the fifth year.

These extended warranties apply only to new equipment installed in domestic Worldwide Applied Systems Group sales territories and must be ordered prior to startup.



Trane optimizes the performance of homes and buildings around the world. A business of Ingersoll Rand, the leader in creating and sustaining safe, comfortable and energy efficient environments, Trane offers a broad portfolio of advanced controls and HVAC systems, comprehensive building services, and parts. For more information, visit [www.Trane.com](http://www.Trane.com).

Trane has a policy of continuous product and product data improvement and reserves the right to change design and specifications without notice.

© 2011 Trane All rights reserved  
WSHP-SVX11A-EN 15 Dec 2011  
Supersedes WSHP-SVX11A-EN (May 2009)

We are committed to using environmentally  
conscious print practices that reduce waste.

